

U20EE724-Power Quality Improvement Techniques

Unit1-Introduction to Power Quality

Terms and definitions: Overloading - under voltage - over voltage. Concepts of transients - short duration variations such as interruption - long duration variation such as sustained interruption. Sags and swells - voltage sag - voltage swell - voltage imbalance - voltage fluctuation - power frequency variations. International standards of power quality. Computer Business Equipment Manufacturers Associations (CBEMA) curve

Introduction

- ✓ Power quality is any abnormal behavior on a power system arising in the form of voltage or current, which affects the normal operation of electrical or electronic equipment.
- ✓ Power quality is any deviation of the voltage or current waveform from its normal sinusoidal wave shape.
- ✓ Power quality has been defined as the parameters of the voltage that affect the customer's supersensitive equipment.
- ✓ Power quality problems are
 - Voltage sag
 - Voltage swell
 - Voltage Flicker
 - Harmonics
 - Over voltage
 - Under voltage
 - Transients
- ✓ Voltage sags are considered the most common power quality problem. These can be caused by the utility or by customer loads. When sourced from the utility, they are most commonly caused by faults on the distribution system. These sags will be from 3 to 30 cycles and can be single or three phase. Depending on the design of the distribution system, a ground fault on 1 phase can cause a simultaneous swell on another phase.
- ✓ Power quality problems are related to grounding, ground bonds and neutral to ground voltages, ground loops, ground current or ground associated issues.

- ✓ Harmonics are distortions in the AC waveform. These distortions are caused by loads on the electrical system that use the electrical power at a different frequency than the fundamental 50 or 60 Hz.

Terms and Definitions:

Power Quality:

It is any deviation of the voltage or current waveform from its normal sinusoidal wave shape.

Voltage quality:

Deviations of the voltage from a sinusoidal waveform.

Current quality:

Deviations of the current from a sinusoidal waveform.

Frequency Deviation:

An increase or decrease in the power frequency.

Impulsive transient:

A sudden, non power frequency change in the steady state condition of voltage or current that is unidirectional in polarity.

Oscillatory transients:

A sudden, non power frequency change in the steady state condition of voltage or current that is bidirectional in polarity.

DC Offset:

The presence of a DC voltage or current in an AC power system.

Noises:

An unwanted electric signal in the power system.

Long duration Variation:

A variation of the RMS value of the voltage from nominal voltage for a time greater than 1 min.

Short Duration Variation:

A variation of the RMS value of the voltage from nominal voltage for a time less than 1 min.

Sag:

A decrease in RMS value of voltage or current for durations of 0.5 cycles to 1 min.

Swell:

A Temporary increase in RMS value of voltage or current for durations of 0.5 cycles to 1 min.

Under voltage:

10% below the nominal voltage for a period of time greater than 1 min.

Over voltage:

10% above the nominal voltage for a period of time greater than 1 min.

Voltage fluctuation:

A cyclical variation of the voltage that results in flicker of lightning.

Voltage imbalance:

Three phase voltages differ in amplitude.

Harmonic:

It is a sinusoidal component of a periodic wave or quantity having a frequency that is an integral multiple of the fundamental power frequency.

Distortion:

Any deviation from the normal sine wave for an AC quantity.

Total Harmonic Distortion:

The ratio of the root mean square of the harmonic content to the RMS value of the fundamental quantity.

$$\text{THD} = \frac{\sqrt{\sum_{h > 1}^{h_{\max}} M_h^2}}{M_1}$$

Interruption:

The complete loss of voltage on one or more phase conductors for a time greater than 1 min.

Concepts of transients:

- ✓ Transient over voltages in electrical transmission and distribution networks result from the unavoidable effects of lightning strike and network switching operations.\
- ✓ Response of an electrical network to a sudden change in network conditions.
- ✓ Oscillation is an effect caused by a transient response of a circuit or system. It is a momentary event preceding the steady state (electronics) during a sudden change of a circuit.
- ✓ An example of transient oscillation can be found in digital (pulse) signals in computer networks. Each pulse produces two transients, an oscillation resulting from the sudden rise in voltage and another oscillation from the sudden drop in voltage. This is generally considered an undesirable effect as it introduces variations in the high and low voltages of a signal, causing instability.
- ✓ Types of transient:
 - Impulsive transient
 - Oscillatory transient

Impulse transient:

A sudden, non power frequency change in the steady state condition of voltage or current that is unidirectional in polarity.

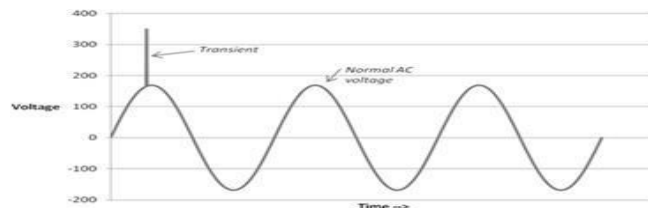

Oscillatory transient:

A sudden, non power frequency change in the steady state condition of voltage or current that is bidirectional in polarity.

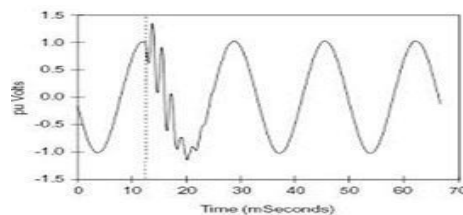

Short duration variations – Interruption

The complete loss of voltage on one or more phase conductors for a time less than 1 min.

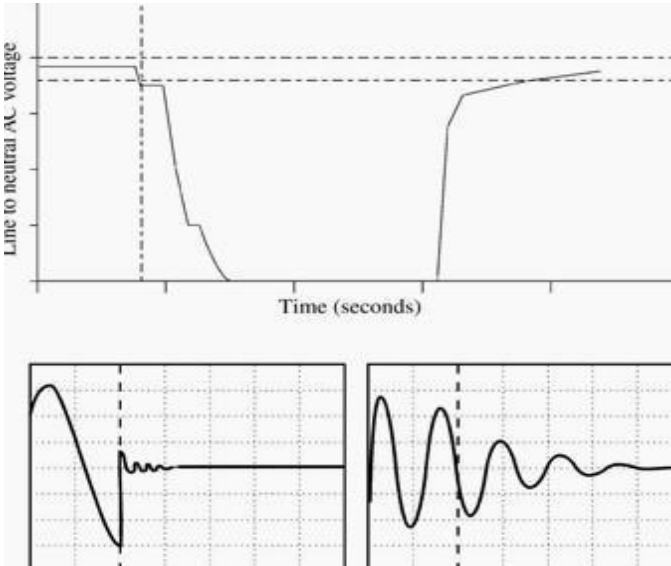

Types of Short Duration interruption:

- ✓ Momentary Interruption < 1 min , <0.1 pu
- ✓ Temporary Interruption < 1 min , <0.1 pu

Long duration variations – Sustained interruption

The complete loss of voltage on one or more phase conductors for a time greater than 1 min.

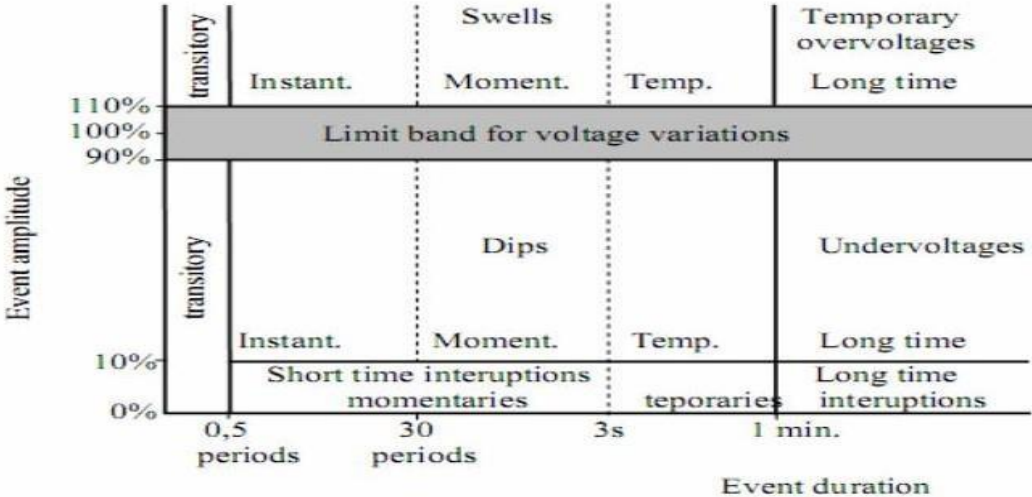

Sags and Swells:

Voltage sag:

- ✓ A **voltage sag** or **voltage dip** is a short duration reduction in RMS voltage which can be caused by a short circuit, overload or starting of electric motors.
- ✓ Voltage sag happens when the RMS voltage decreases between 10 and 90 percent of nominal voltage for one-half cycle to one minute.
- ✓ Some references define the duration of sag for a period of 0.5 cycles to a few seconds, and longer duration of low voltage would be called "sustained sag".

There are several factors which cause voltage sag to happen:

- ✓ Since the electric motors draw more current when they are starting than when they are running at their rated speed, starting an electric motor can be a reason of voltage sag.
- ✓ When a line-to-ground fault occurs, there will be voltage sag until the protective switch gear operates.
- ✓ Some accidents in power lines such as lightning or falling an object can be a cause of line-to-ground fault and voltage sag as a result.
- ✓ Sudden load changes or excessive loads can cause voltage sag.
- ✓ Depending on the transformer connections, transformers energizing could be another reason for happening voltage sags.
- ✓ Voltage sags can arrive from the utility but most are caused by in-building equipment. In residential homes, we usually see voltage sags when the refrigerator, air-conditioner or furnace fan starts up.

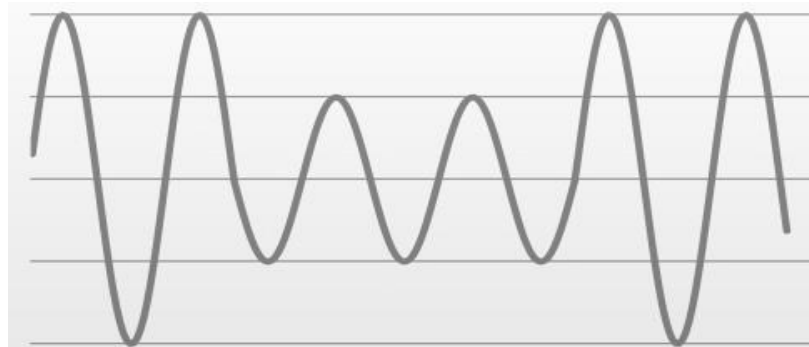

Voltage Swell:

- ✓ Swell - an increase to between 1.1pu and 1.8 pu in rms voltage or current at the power frequency durations from 0.5 to 1 minute
- ✓ In the case of a voltage swell due to a single line-to-ground (SLG) fault on the system, the result is a temporary voltage rise on the un faulted phases, which last for the duration of the fault. This is shown in the figure below:

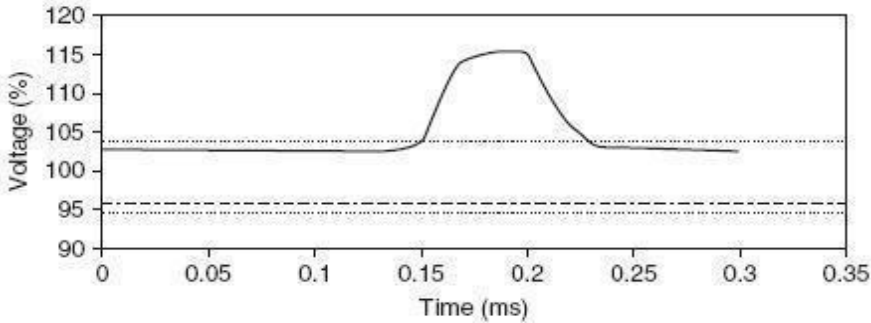

Instantaneous Voltage Swell Due to SLG fault

- ✓ Voltage swells can also be caused by the deenergization of a very large load.
- ✓ It may cause breakdown of components on the power supplies of the equipment, though the effect may be a gradual, accumulative effect. It can cause control problems and hardware failure in the equipment, due to overheating that could eventually result to shutdown. Also, electronics and other sensitive equipment are prone to damage due to voltage swell.

Voltage Swell	Magnitude	Duration
Instantaneous	1.1 to 1.8 pu	0.5 to 30 cycles
Momentary	1.1 to 1.4 pu	30 cycles to 3 sec
Temporary	1.1 to 1.2 pu	3 sec to 1 min

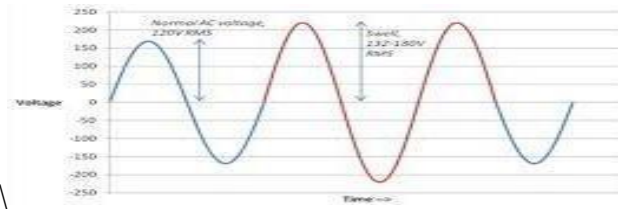

Voltage unbalance:

- ✓ In a balanced sinusoidal supply system the three line-neutral voltages are equal in magnitude and are phase displaced from each other by 120 degrees (Figure 1). Any differences that exist in the three voltage magnitudes and/or a shift in the phase separation from 120 degrees is said to give rise to an unbalanced supply (Figure 2)

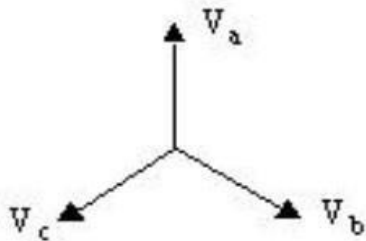

Figure 1 A balanced system

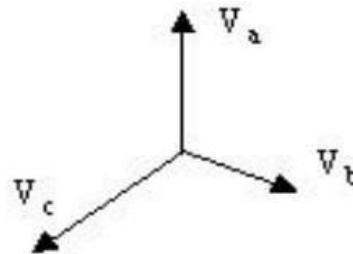
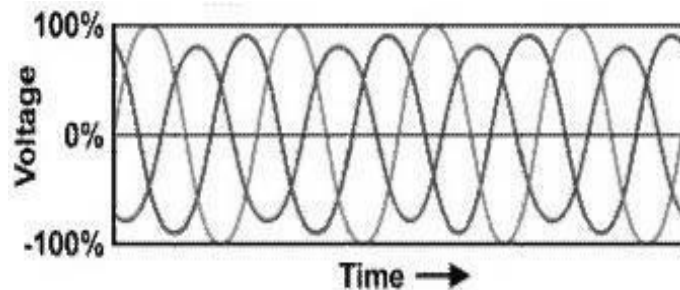

Figure 2 An unbalanced system



- ✓ The utility can be the source of unbalanced voltages due to malfunctioning equipment, including blown capacitor fuses, open-delta regulators, and open-delta transformers. Open-delta equipment can be more susceptible to voltage unbalance than closed-delta since they only utilize two phases to perform their transformations.
- ✓ Also, voltage unbalance can also be caused by uneven single-phase load distribution among the three phases - the likely culprit for a voltage unbalance of less than 2%. Furthermore, severe cases (greater than 5%) can be attributed to

single-phasing in the utility's distribution lateral feeders because of a blown fuse due to fault or overloading on one phase.

Voltage Fluctuation:

- ✓ Voltage fluctuations can be described as repetitive or random variations of the voltage envelope due to sudden changes in the real and reactive power drawn by a load. The characteristics of voltage fluctuations depend on the load type and size and the power system capacity.
- ✓ Figure 1 illustrates an example of a fluctuating voltage waveform. The voltage waveform exhibits variations in magnitude due to the fluctuating nature or intermittent operation of connected loads.
- ✓ The frequency of the voltage envelope is often referred to as the flicker frequency. Thus there are two important parameters to voltage fluctuations, the frequency of fluctuation and the magnitude of fluctuation. Both of these components are significant in the adverse effects of voltage fluctuations.

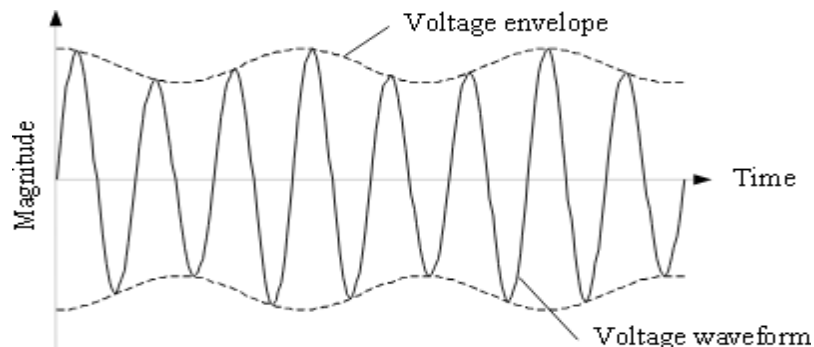

- ✓ Voltage fluctuations are caused when loads draw currents having significant sudden or periodic variations. The fluctuating current that is drawn from the supply causes additional voltage drops in the power system leading to fluctuations in the supply voltage. Loads that exhibit continuous rapid variations are thus the most likely cause of voltage fluctuations.
- ✓ Arc furnaces
- ✓ Arc welders
- ✓ Installations with frequent motor starts (air conditioner units, fans)
- ✓ Motor drives with cyclic operation (mine hoists, rolling mills)
- ✓ Equipment with excessive motor speed changes (wood chippers, car shredders)

Power frequency variations:

- ✓ Power frequency variations are a deviation from the nominal supply frequency. The supply frequency is a function of the rotational speed of the generators used to produce the electrical energy.
- ✓ At any instant, the frequency depends on the balance between the load and the capacity of the available generation.
- ✓ A frequency variation occurs if a generator becomes un-synchronous with the power system, causing an inconsistency that is manifested in the form of a variation.
- ✓ The specified frequency variation should be within the limits $\pm 2.5\%$ Hz at all times for grid network.

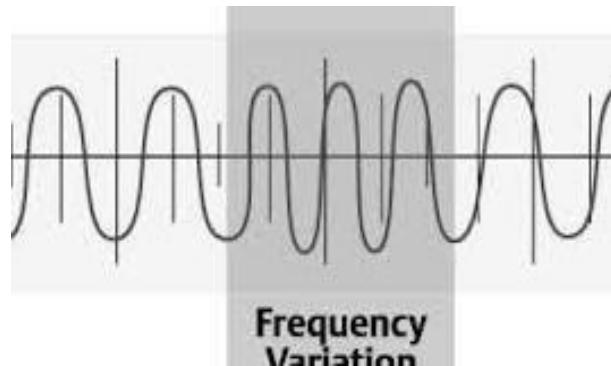

International Standards of power quality:

IEEE Standards:

- ✓ IEEE power quality standards: Institute Of Electrical and Electronics Engineer.
- ✓ IEEE power quality standards: International Electro Technical Commission.
- ✓ IEEE power quality standards: Semiconductor Equipment and Material International.
- ✓ IEEE power quality standards: The International Union for Electricity Applications
- ✓ IEEE Std 519-1992: IEEE Recommended practices and requirements for Harmonic control in Electric power systems.
- ✓ IEEE Std 1159-1995: IEEE Recommended practices for monitoring electrical power
- ✓ IEEE std 141-1993, IEEE Recommended practice for electric power distribution for industrial plants.
- ✓ IEEE std 1159-1995, IEEE recommended practice for Monitoring electrical power quality.

IEC Standards:

- ✓ Definitions and methodology 61000-1-X
- ✓ Environment 61000-2-X
- ✓ Limits 61000-3-X
- ✓ Tests and measurements 61000-4-X
- ✓ Installation and mitigation 61000-5-X
- ✓ Generic immunity and emissions 61000-6-X

CBEMA and ITI Curves:

- ✓ One of the most frequently employed displays of data to represent the power quality is the so-called CBEMA curve.
- ✓ A portion of the curve adapted from IEEE Standard 4469 that we typically use in our analysis of power quality monitoring results is shown in Fig. 1.5.
- ✓ This curve was originally developed by CBEMA to describe the tolerance of mainframe computer equipment to the magnitude and duration of voltage variations on the power system.
- ✓ While many modern computers have greater tolerance than this, the curve has become a standard design target for sensitive equipment to be applied on the power system and a common format for reporting power quality variation data.
- ✓ The axes represent magnitude and duration of the event. Points below the envelope are presumed to cause the load to drop out due to lack of energy. Points above the envelope are presumed to cause other malfunctions such as insulation failure, overvoltage trip, and over excitation.
- ✓ The upper curve is actually defined down to 0.001 cycle where it has a value of about 375 percent voltage.
- ✓ We typically employ the curve only from 0.1 cycles and higher due to limitations in power quality monitoring instruments and differences in opinion over defining the magnitude values in the sub cycle time frame.
- ✓ The CBEMA organization has been replaced by ITI, and a modified curve has been developed that specifically applies to common 120-V computer equipment (see Fig. 1.6). The concept is similar to the CBEMA curve. Although developed for 120-V

computer equipment, the curve has been applied to general power quality evaluation like its predecessor curve.

- ✓ Both curves are used as a reference in this book to define the withstand capability of various loads and devices for protection from power quality variations.
- ✓ For display of large quantities of power quality monitoring data, we frequently add a third axis to the plot to denote the number of events within a certain predefined cell of magnitude and duration.

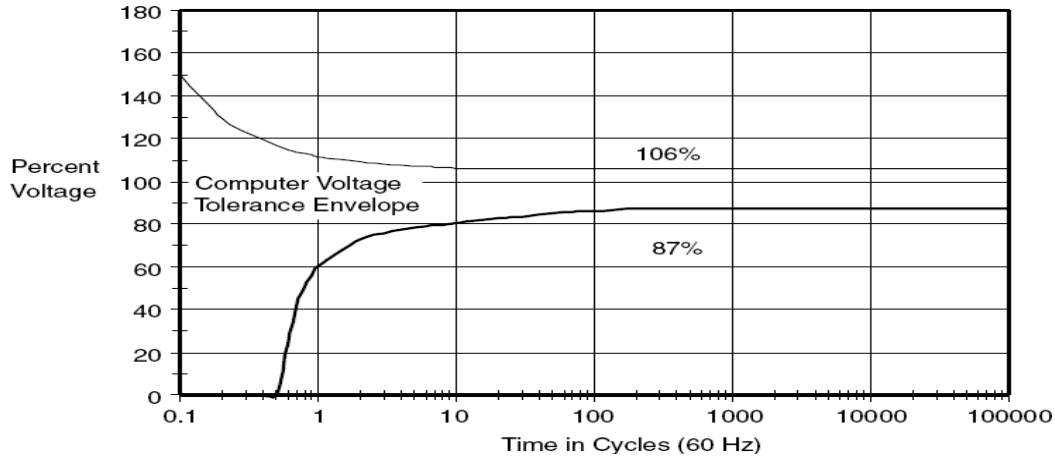

Fig 1.5 A portion of the CBEMA curve commonly used as a design target for equipment
And a format for reporting power quality variation data.

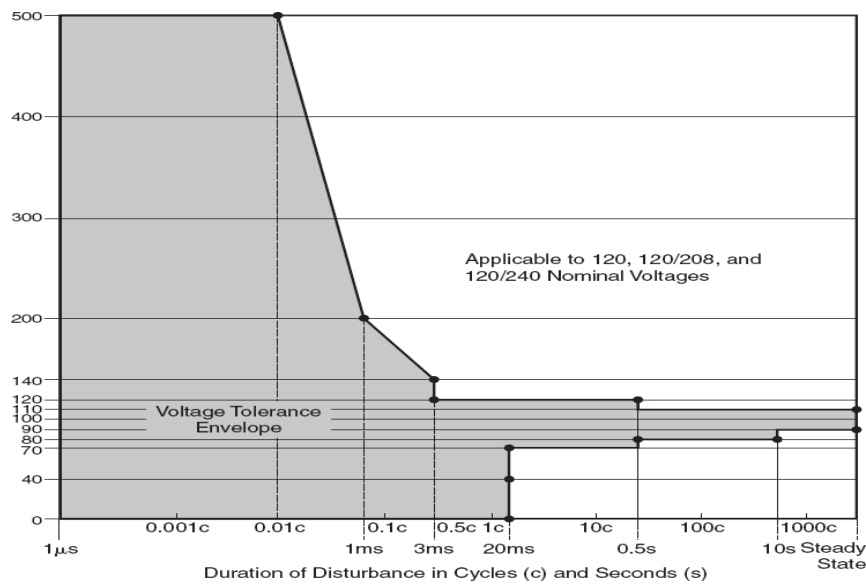

Fig 1.6 ITI curve for susceptibility of 120-V computer equipment.

Unit-2

Voltage Sags and Interruptions

Sources of sags and interruptions - estimating voltage sag performance. Thevenin's equivalent source - analysis and calculation of various faulted condition. Voltage sag due to induction motor Starting. Estimation of the sag severity - mitigation of voltage sags, active series compensators. Static transfer switches and fast transfer switches.

Introduction:

- ✓ Voltage variations, such as voltage sags and momentary interruptions are two of the most important power quality concerns for customers.
- ✓ Voltage sags is the most common type of power quality disturbance in the distribution system.
- ✓ It can be caused by fault in the electrical network or by the starting of a large induction motor.
- ✓ Voltage sag is a reduction in voltage for a short time.
- ✓ A voltage sag or voltage dip is a short duration reduction in RMS voltage which can be caused by a short circuit, overload or starting of electric motors.

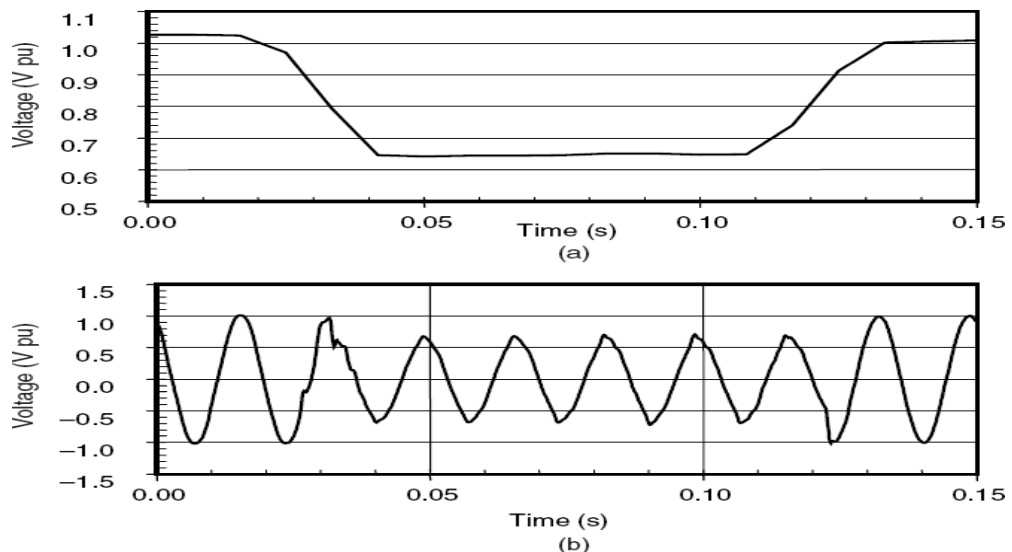

Figure 1.1 Voltage sag caused by an SLG fault. (a) RMS waveform for voltage sag event. (b) Voltage sag waveform.

Sources of sags and interruptions:

- ✓ A sudden increase in load results in a corresponding sudden drop in voltage.
- ✓ Any sudden increase in load, if large enough, will cause a voltage sag in:
 - Motors
 - Faults cause the voltage sag.
 - Switching operation
- ✓ Since the electric motors draw more current when they are starting than when they are running at their rated speed, starting an electric motor can be a reason of voltage sag.
- ✓ When a line-to-ground fault occurs, there will be voltage sag until the protective switch gear operates.
- ✓ Some accidents in power lines such as lightning or falling an object can be a cause of line-to-ground fault and voltage sag as a result.
- ✓ Sudden load changes or excessive loads can cause voltage sag.
- ✓ Depending on the transformer connections, transformers energizing could be another reason for happening voltage sags.
- ✓ Voltage sags can arrive from the utility but most are caused by in-building equipment. In residential homes, we usually see voltage sags when the refrigerator, air-conditioner or furnace fan starts up.

Estimating Voltage sag Performance:

Introduction:

It is important to understand the expected voltage sag performance of the supply system so that facilities can be designed and equipment specifications developed to assure the optimum operation of production facilities. The following is a general procedure for working with industrial customers to assure compatibility between the supply system characteristics and the facility operation:

- ✓ Determine the number and characteristics of voltage sags that result from transmission system faults.

- ✓ Determine the number and characteristics of voltage sags that result from distribution system faults (for facilities that are supplied from distribution systems).
- ✓ Determine the equipment sensitivity to voltage sags. This will determine the actual performance of the production process based on voltage sag performance calculated in steps 1 and 2.
- ✓ Evaluate the economics of different solutions that could improve the performance, either on the supply system or within the customer facility.

Area of vulnerability

The concept of an *area of vulnerability* has been developed to help evaluate the likelihood of sensitive equipment being subjected to voltage lower than its *minimum voltage sag ride-through capability*.⁵ The latter term is defined as the minimum voltage magnitude a piece of equipment can withstand or tolerate without misoperation or failure. This is also known as the equipment voltage sag immunity or susceptibility limit. An area of vulnerability is determined by the total circuit miles of exposure to faults that can cause voltage magnitudes at an end-user facility to drop below the equipment minimum voltage sag ride-through capability. Figure 2.5 shows an example of an area of vulnerability diagram for motor contactor and adjustable-speed-drive loads at an end-user facility served from the distribution system. The loads will be subject to faults on both the transmission system and the distribution system.

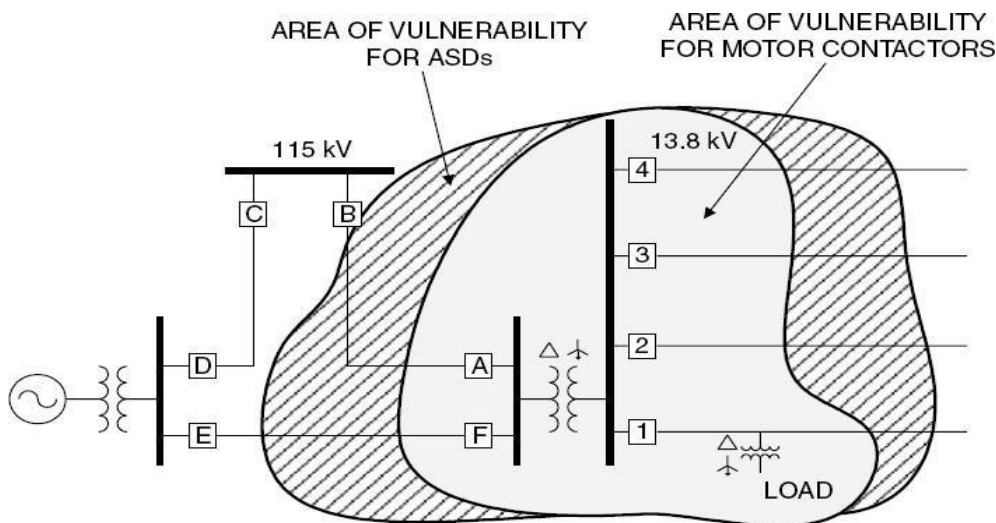

Fig 1.1 Illustration of an area of vulnerability

Equipment sensitivity to voltage sags

Equipment within an end-user facility may have different sensitivity to voltage sags. Equipment sensitivity to voltage sags is very dependent on the specific load type, control settings, and applications. Consequently, it is often difficult to identify which characteristics of a given voltage sag are most likely to cause equipment to misoperate. The most commonly used characteristics are the duration and magnitude of the sag. Other less commonly used characteristics include phase shift and unbalance, missing voltage, three-phase voltage unbalance during the sag event, and the point-in-the-wave at which the sag initiates and terminates.

Generally, equipment sensitivity to voltage

sags can be divided into three categories:

- 1. Equipment sensitive to only the magnitude of a voltage sag.*
- 2. Equipment sensitive to both the magnitude and duration of a voltage sag.*
- 3. Equipment sensitive to characteristics other than magnitude and duration.*

Equipment sensitive to only the magnitude of a voltage sag:

This group includes devices such as under voltage relays, process controls, motor drive controls, and many types of automated machines (e.g., semiconductor manufacturing equipment). Devices in this group are sensitive to the minimum (or maximum) voltage magnitude experienced during a sag (or swell). The duration of the disturbance is usually of secondary importance for these devices.

Equipment sensitive to both the magnitude and duration of a voltage sag:

This group includes virtually all equipment that uses electronic power supplies. Such equipment misoperates or fails when the power supply output voltage drops below specified values. Thus, the important characteristic for this type of equipment is the duration

that the rms voltage is below a specified threshold at which the equipment trips.

Equipment sensitive to characteristics other than magnitude and duration:

Some devices are affected by other sag characteristics such as the phase unbalance during the sag event, the point-in-the wave at which the sag is initiated, or any transient

oscillations occurring during the disturbance. These characteristics are more subtle than magnitude and duration, and their impacts are much more difficult to generalize. As a result, the rms variation performance indices defined here are focused on the more common magnitude and duration characteristics.

For end users with sensitive processes, the voltage sag ride-through capability is usually the most important characteristic to consider. These loads can generally be impacted by very short duration events, and virtually all voltage sag conditions last at least 4 or 5 cycles (unless the fault is cleared by a current-limiting fuse). Thus, one of the most common methods to quantify equipment susceptibility to voltage sags is using a magnitude-duration plot as shown in Fig. 2.6. It shows the voltage sag magnitude that will cause equipment to misoperate as a function of the sag duration.

The curve labeled CBEMA represents typical equipment sensitivity characteristics. The curve was developed by the CBEMA and was adopted in IEEE 446 (Orange Book). Since the association reorganized in 1994 and was subsequently renamed the Information Technology Industry Council (ITI), the CBEMA curve was also updated and renamed the ITI curve. Typical loads will likely trip off when the voltage is below the CBEMA, or ITI, curve.

The curve labeled ASD represents an example ASD voltage sag ride through capability for a device that is very sensitive to voltage sags. It trips for sags below 0.9 pu that last for only 4 cycles. The contactor curve represents typical contactor sag ride-through characteristics. It trips for voltage sags below 0.5 pu that last for more than 1 cycle.

The area of vulnerability for motor contactors shown in Fig. 2.5 indicates that faults within this area will cause the end-user voltage to drop below 0.5 pu. Motor contactors having a minimum voltage sag ride-through capability of 0.5 pu would have tripped out when a fault causing a voltage sag with duration of more than 1 cycle occurs within the area of vulnerability.

However, faults outside this area will not cause the voltage to drop below 0.5 pu.

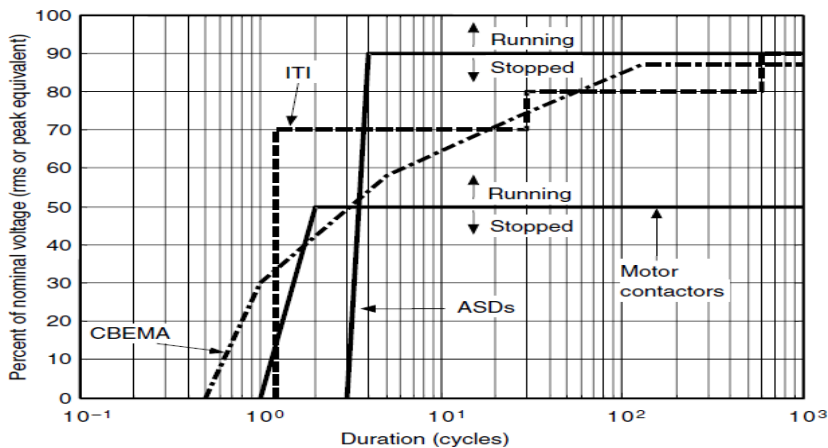

Fig 2.6 Typical equipment voltage sag ride through capability curves.

2.3.3.4 Transmission system sag performance evaluation

The voltage sag performance for a given customer facility will depend on whether the customer is supplied from the transmission system or from the distribution system. For a customer supplied from the transmission system, the voltage sag performance will depend on only the transmission system fault performance. On the other hand, for a customer supplied from the distribution system, the voltage sag performance will depend on the fault performance on both the transmission and distribution systems.

Transmission line faults and the subsequent opening of the protective devices rarely cause an interruption for any customer because of the interconnected nature of most modern-day transmission networks. These faults do, however, causes voltage sags. Depending on the equipment sensitivity, the unit may trip off, resulting in substantial monetary losses.

ASPEN (Advanced System for Power Engineering) programs can calculate the voltage throughout the system resulting from fault around the system. It is also calculate the area of vulnerability in the specific location.

Utility distribution system sag performance evaluation

Customers that are supplied at distribution voltage levels are impacted by faults on both the transmission system and the distribution system. The analysis at the distribution level must

also include momentary interruptions caused by the operation of protective devices to clear the faults.

Figure 2.2 shows a typical distribution system with multiple feeders and fused branches, and protective devices. The utility protection scheme plays an important role in the voltage sag and momentary interruption performance. The critical information needed to compute voltage sag performance can be summarized as follows:

- Number of feeders supplied from the substation.
- Average feeder length.
- Average feeder reactance.
- Short-circuit equivalent reactance at the substation.

They are two possible locations for faults on the distributed system (i.e) On the same feeder and on parallel feeder.

Voltage sags due to induction motor starting:

Voltage sags can causes:

- ✓ Motor load to start/ stop
- ✓ Digital devices to reset causing loss of data
- ✓ Equipment damage and /or failure
- ✓ Materials spoilage
- ✓ Lost production due to downtime
- ✓ Additional costs
- ✓ Product reworks
- ✓ Product quality impacts
- ✓ Cost of investigations into problem
- ✓ Impacts on customer relations such as late delivery.
- ✓ Lost of sales

Voltage sags due to Motor Starting:

- ✓ Voltage sag produced by induction motor starting current is one of the main causes of sensitive equipment dropout.
- ✓ The use of motor starter reduces the voltage sag depth but increases its duration.
- ✓ The subsequent connection to full voltage originates new sag separated from the first one by a few seconds.
- ✓ An induction motor will draw six to ten times its full load current while starting.
- ✓ This lagging current then causes a voltage drop across the impedance of the system.
- ✓ Generally induction motors are balanced 3 phase loads, voltage sags due to their starting are symmetrical.
- ✓ Each phase draws approximately the same in rush current. The magnitude of voltage sag depends on,
- ✓ Characteristics of the induction motor
- ✓ Strength of the system at the point where motor is connected.

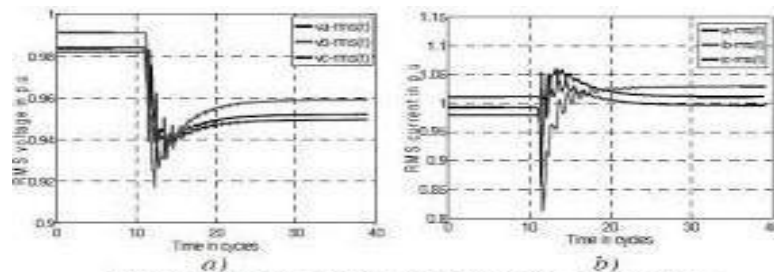
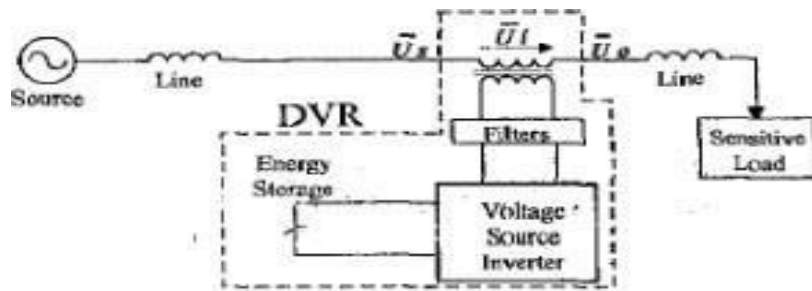

Figure 6. Voltage sag registered at node S90: a) rms voltage
b) rms current.

Estimation of the Sag Severity:

. If full-voltage starting is used, the sag voltage, in per unit of nominal system voltage, is

$$V_{\text{Min}}(\text{pu}) = \frac{V(\text{pu}) \cdot \text{kVA}_{\text{SC}}}{\text{kVA}_{\text{LR}} + \text{kVA}_{\text{SC}}}$$

Where $V(\text{pu})$ = actual system voltage, in per unit of nominal, kVA_{LR} = motor locked rotor kVA

kVA_{SC} = system short-circuit kVA at motor

If the result is above the minimum allowable steady-state voltage for the affected equipment, then the full-voltage starting is acceptable. If not, then the sag magnitude versus duration characteristic must be compared to the voltage tolerance envelope of the affected equipment. The required calculations are fairly complicated and best left to a motor-starting or general transient analysis computer program. The following data will be required for the simulation:

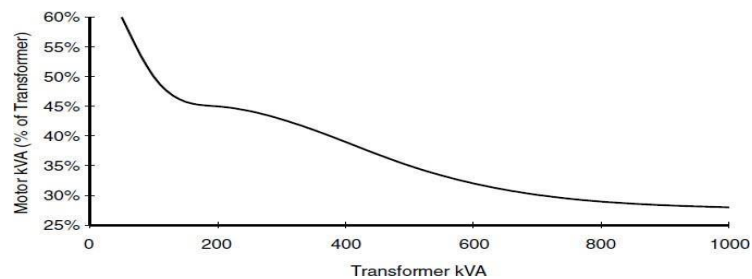

Fig Typical motor versus transformer size for full-voltage starting sags of 90 percent.

- Parameter values for the standard induction motor equivalent circuit: R_1 , X_1 , R_2 , X_2 , and XM .
- Number of motor poles and rated rpm (or slip).
- WK^2 (inertia constant) values for the motor and the motor load.
- Torque versus speed characteristic for the motor load.

Mitigation of Voltage Sags:

- ✓ Different power quality problems would require different solution. It would be very costly to decide on mitigate measure that do not or partially solve the problem.
- ✓ These costs include lost productivity, labor costs for clean up and restart, damaged product, reduced product quality, delays in delivery and reduced customer satisfaction.
- ✓ When a customer or installation suffers from voltage sag, there is a number of mitigation methods are available to solve the problem.
- ✓ These responsibilities are divided into three parts that involves utility, customer and equipment manufacturer.
- ✓ Different mitigation methods are
 - Dynamic voltage restorer
 - Active series Compensators
 - Distribution static compensator (DSTATCOM)
 - Solid state transfer switch (SSTS)
 - Static UPS with energy storage
 - Backup storage energy supply (BSES)
 - Ferro resonant transformer
 - Flywheel and Motor Generator set
 - Static Var Compensator (SVC)

Dynamic Voltage Restorer: (DVR)

- ✓ Dynamic Voltage Restorers (DVR) are complicated static devices which work by adding the ‘missing’ voltage during a voltage sag. Basically this means that the device injects voltage into the system in order to bring the voltage back up to the level required by the load.
- ✓ Injection of voltage is achieved by a switching system coupled with a transformer which is connected in series with the load.

- ✓ There are two types of DVRs available; those with and without energy storage. Devices without energy storage are able to correct the voltage waveform by drawing additional current from the supply.
- ✓ Devices with energy storage use the stored energy to correct the voltage waveform. The difference between a DVR with storage and a UPS is that the DVR only supplies the part of the waveform that has been reduced due to the voltage sag, not the whole waveform.
- ✓ In addition, DVRs generally cannot operate during interruptions. Figure 10 shows a schematic of a DVR.
- ✓ As can be seen the basic DVR consists of an injection/booster transformer, a harmonic filter, a voltage source converter (VSC) and a control system.
- ✓ For readers who are interested in further knowledge of DVR systems, the article in gives a thorough description of the design and operation of DVRs. DVR systems have the advantage that they are highly efficient and fast acting. It is claimed in that the DVR is the best economic solution for mitigating voltage sags based on its size and capabilities.
- ✓ In the case of systems without storage, none of the inherent issues with storage are relevant. Another advantage of DVR systems is that they can be used for purposes other than just voltage sag mitigation.

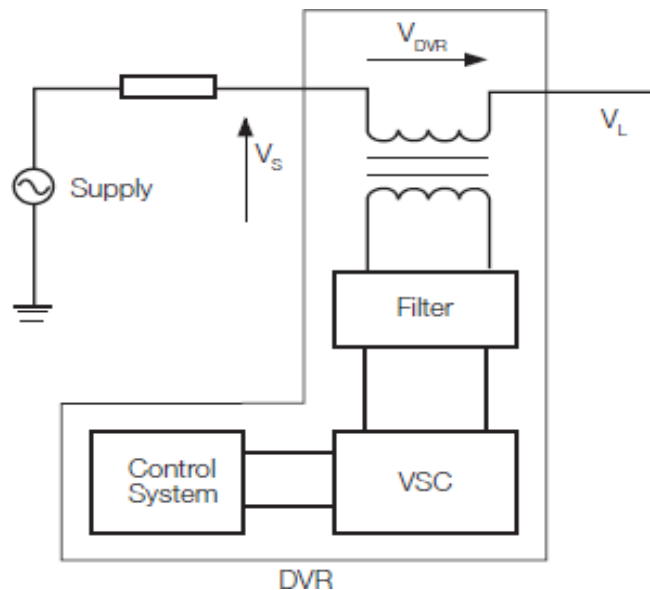

Ferro Resonant Transformer:

- ✓ A Ferro resonant transformer, also known as a constant voltage transformer (CVT), is a transformer that operates in the saturation region of the transformer B-H curve.
- ✓ Voltage sags down to 30 % retained voltage can be mitigated through the use of Ferro resonant transformers.
- ✓ Figure shows a schematic of a Ferro resonant transformer. The effect of operating the transformer in this region is that changes in input voltage only have a small impact on the output voltage.
- ✓ Ferro resonant transformers are simple and relatively maintenance free devices which can be very effective for small loads. Ferro resonant transformers are available in sizes up to around 25 KVA.
- ✓ On the down side, the transformer introduces extra losses into the circuit and is highly inefficient when lightly loaded. In some cases they may also introduce distorted voltages.
- ✓ In addition, unless greatly oversized, Ferro resonant transformers are generally not suitable for loads with high inrush currents such as direct-on-line motors.

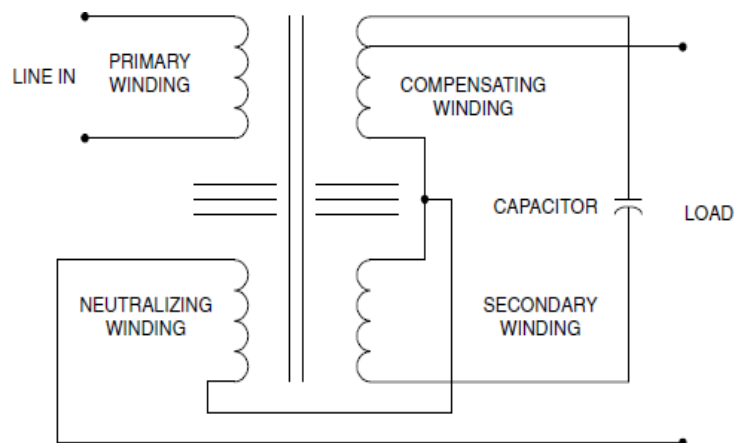

Uninterrupted Power Supply (UPS):

- ✓ Uninterruptible power supplies (UPS) mitigate voltage sags by supplying the load using stored energy. Upon detection of voltage sag, the load is transferred from the mains supply to the UPS.
- ✓ Obviously, the capacity of load that can be supplied is directly proportional to the amount of energy storage available.
- ✓ UPS systems have the advantage that they can mitigate all voltage sags including outages for significant periods of time (depending on the size of the UPS).
- ✓ There are 2 topologies of UPS available; on-line and off-line. Figure 1 shows a schematic of an off-line UPS while Figure 2 shows a schematic of an on-line UPS.
- ✓ Comparison of the figures shows that the difference between the two systems is that for an on-line UPS the load is always supplied by the UPS, while for off-line systems; the load is transferred from the mains supply to the UPS by a static changeover switch upon detection of voltage sag.
- ✓ The lack of a changeover switch renders the on-line system more reliable as any failure of the changeover switch will result in the off-line UPS being ineffective. UPS systems have disadvantages related to energy storage components (mostly batteries) which must be maintained and replaced periodically.
- ✓ Small UPS systems are relatively simple and cheap. However, large units are complex and highly expensive due to the need for large energy storage capacities.
- ✓ **Block Diagram of Offline UPS:**

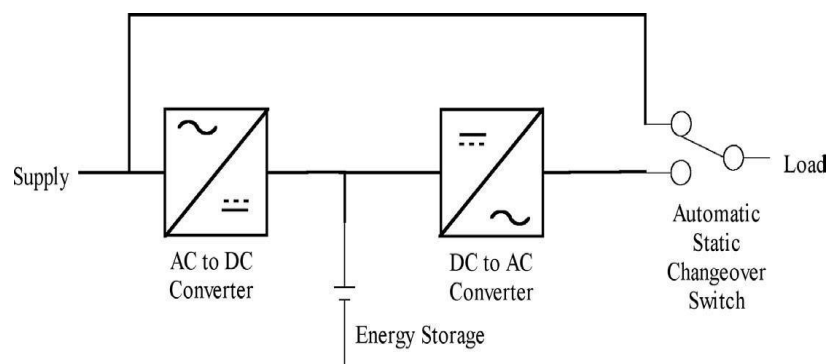

Block Diagram of Online UPS:

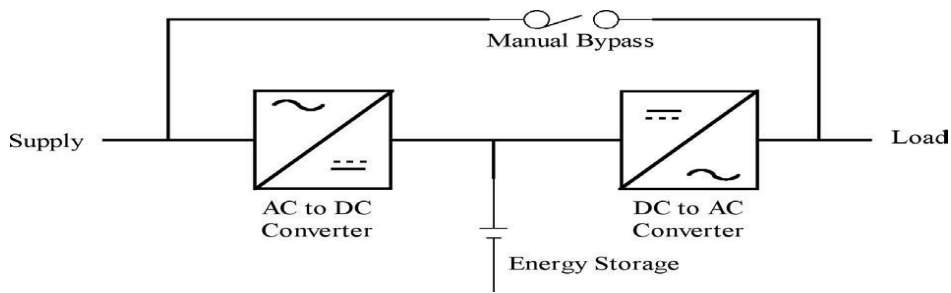

Static Var Compensator:

- ✓ A SVC is a shunt connected power electronics based device which works by injecting reactive current into the load, thereby supporting the voltage and mitigating the voltage sag.
- ✓ SVCs may or may not include energy storage, with those systems which include storage being capable of mitigating deeper and longer voltage sags.

Block Diagram of SVC:

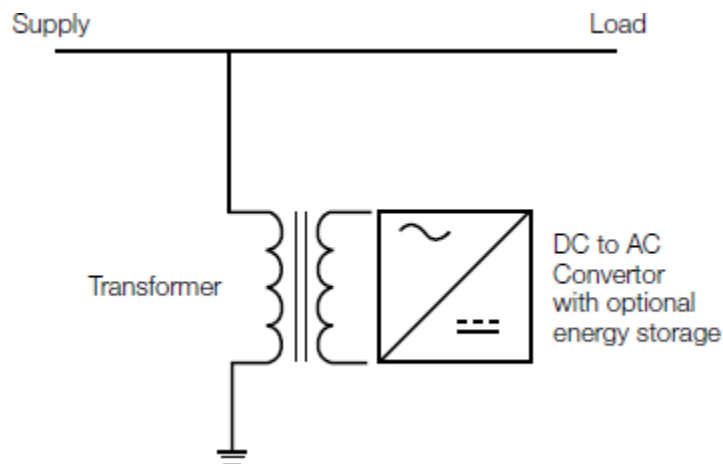

Motor Generator Set:

- ✓ Motor-generator (M-G) sets come in a wide variety of sizes and configurations.
- ✓ This is a mature technology that is still useful for isolating critical loads from sags and interruptions on the power system.
- ✓ A motor powered by the line drives a generator that powers the load. Flywheels on the same shaft provide greater inertia to increase ride-through time.

- ✓ When the line suffers a disturbance, the inertia of the machines and the flywheels maintains the power supply for several seconds.
- ✓ This arrangement may also be used to separate sensitive loads from other classes of disturbances such as harmonic distortion and switching transients.
- ✓ While simple in concept, M-G sets have disadvantages for some types of loads:
 1. There are losses associated with the machines, although they are not necessarily larger than those in other technologies described here.
 2. Noise and maintenance may be issues with some installations.
 3. The frequency and voltage drop during interruptions as the machine slows. This may not work well with some loads.
- ✓ Another type of M-G set uses a special synchronous generator called a written-pole motor that can produce a constant 60-Hz frequency as the machine slows.
- ✓ It is able to supply a constant output by continually changing the polarity of the rotor's field poles.
- ✓ Thus, each revolution can have a different number of poles than the last one. Constant output is maintained as long as the rotor is spinning at speeds between 3150 and 3600 revolutions per minute (rpm).
- ✓ Flywheel inertia allows the generator rotor to keep rotating at speeds above 3150 rpm once power shuts off.
- ✓ The rotor weight typically generates enough inertia to keep it spinning fast enough to produce 60 Hz for 15 s under full load.
- ✓ Another means of compensating for the frequency and voltage drop while energy is being extracted is to rectify the output of the generator and feed it back into an inverter.
- ✓ This allows more energy to be extracted, but also introduces losses and cost.

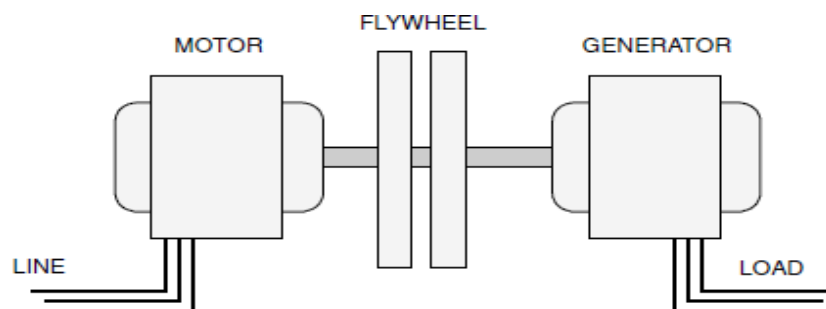

Active series compensators

- ✓ Advances in power electronic technologies and new topologies for these devices have resulted in new options for providing voltage sag ride through support to critical loads. One of the important new options is a device that can boost the voltage by injecting a voltage in series with the remaining voltage during a voltage sag condition.
- ✓ These are referred to as active series compensation devices. They are available in size ranges from small single-phase devices (1 to 5 KVA) to very large devices that can be applied on the medium-voltage systems (2 MVA and larger).
- ✓ Figure shows an example of a small single-phase compensator that can be used to provide ride-through support for single-phase loads.
- ✓ A one-line diagram illustrating the power electronics that are used to achieve the compensation is shown in Fig. When a disturbance to the input voltage is detected, a fast switch opens and the power is supplied through the series-connected electronics.
- ✓ This circuit adds or subtracts a voltage signal to the input voltage so that the output voltage remains within a specified tolerance during the disturbance. The switch is very fast so that the disturbance seen by the load is less than a quarter cycle in duration. This is fast enough to avoid problems with almost all sensitive loads. The circuit can provide voltage boosting of about 50 percent, which is sufficient for almost all voltage sag conditions.

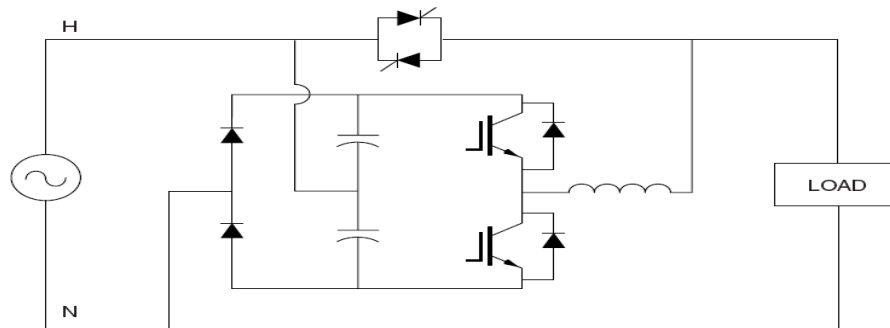

Fig Topology illustrating the operation of the active series compensator.

Static Transfer Switches:

- ✓ The static transfer switch (STS) is an electrical device that allows instantaneous transfer of power source to the load. If one power source fails, the STS to backup power source.
- ✓ A static transfer switch used to switch between a primary supply and a backup supply in the event of a disturbance. The controls would switch back to the primary supply after normal power is restored.

Classification of STS

- Low voltage STS (Vt Up to 600Vt, Ct rating from 200 amps to 4000 amps)
- Medium voltage STS (Vt from 4.61 KV to 34.5 KV)
 - ✓ Fast acting STS's that can transfer between two power source in four to zero milliseconds are increasingly being applied to protect large loads and entire load facilities from short duration power disturbance.
 - ✓ These products use solid state power electronics or static switches as compared to electromechanical switches, which are slow for the application.

The basic STS unit consists of three major parts

- Control and Metering
- Silicon controlled rectifier
- Breakers/ Bus assembly

Fast Transfer Switch (FTS)

- ✓ FTS is used to obtain the minimum time of switch between two sources of power. This can be achieved by analyzing the phase shift between sine waves of two power sources.
- ✓ FTS permits to control zero phase shifts between input signals of power sources. These signals are passed through A/D converter and then to PLB form the control signal for solid state relay to secure the moment of zero phase shifts between input signals.

- ✓ It increases the speed of connecting the load to the power sources with optimal parameters.

Performance of Fast Transfer Switches:

- ✓ Under normal condition the voltage and frequency of power sources1 and power sources2 are inside suitable range of tolerance and load get power from PS1 through closed SSR1.
- ✓ ZD1 and ZD2 form menders from input sine wave signal. Generate the control signal from PLB the unit of ADC converter input voltage from PS1, PS2.
- ✓ In PLB, the measured the value with reference minimum and maximum value of input output voltage are compared.
- ✓ If any measured value of signal from PS1 is out of tolerance then should be formed the signal to the switch the load to PS2.
- ✓ The same procedure is used t control the frequency of input signal and phase shift between PS1 and PS2.
- ✓ If any parameter of signal power source is changed then ADC would form the value of code and this value goes to PLB.
- ✓ After comparing the measurement value of input voltage with minimum and maximum accepted values.
- ✓ If the signal will be formed to switch off the SSR1 means signal to switch on the SSR2 will form is according with synchronism and phase shift between signals from PS1 and PS2.
- ✓ In general any case failure of one commercial source of power, the switch transfers the load to another source in very short time.
- ✓ It is also achieve by synchronized phase control of signal from both power sources. It makes possible to choose the power source during the time interval less than 1ms.

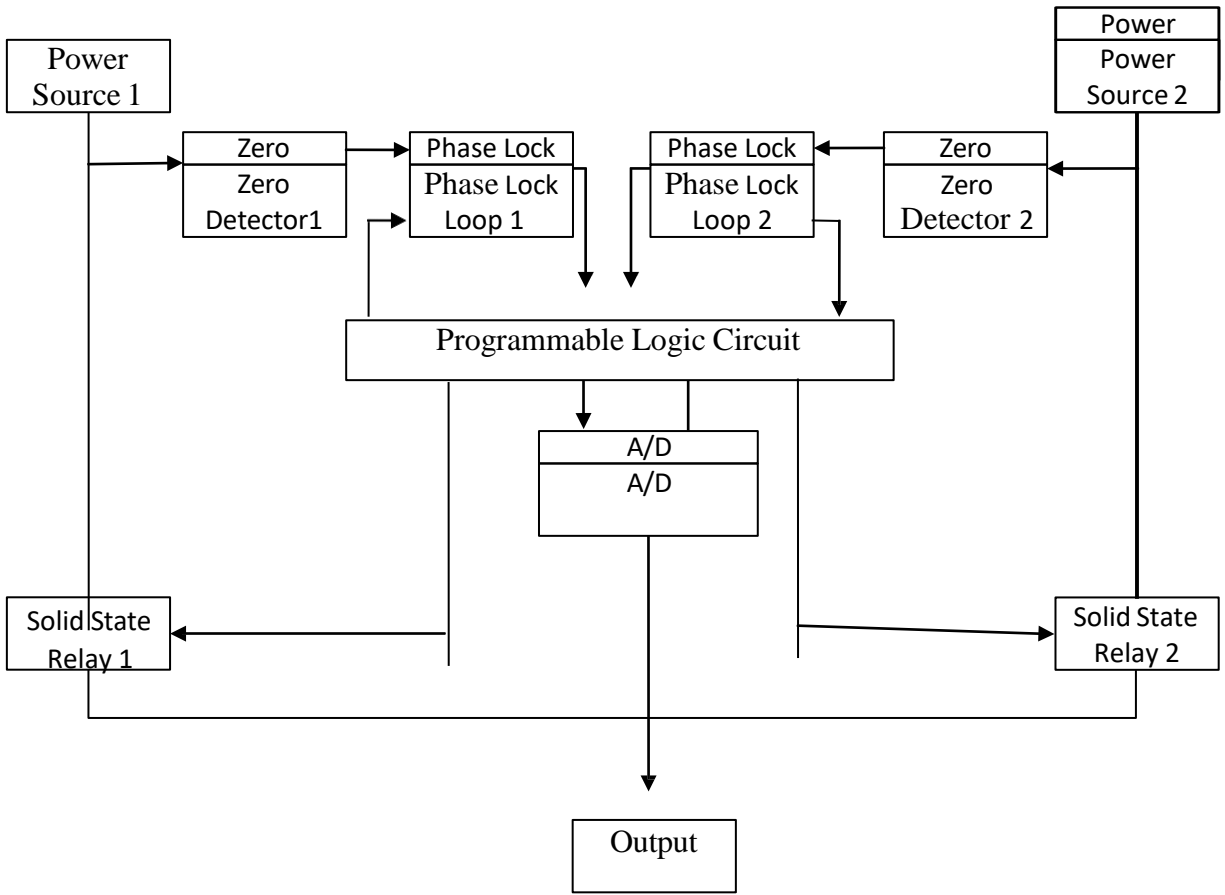

Fig Structure of FTS

Unit-3

Over Voltages

Sources of over voltages - Capacitor switching – lightning - ferro resonance. Mitigation of voltage swells - surge arresters - low pass filters - power conditioners. Lightning protection – shielding – line arresters - protection of transformers and cables. An introduction to computer analysis tools for transients, PSCAD and EMTP.

Introduction:

- ✓ Transient over voltages in electrical transmission and distribution networks result from the unavoidable effects of lightning strikes and network switching operations.
- ✓ These over voltages have the potential to result in large financial losses each year due to damaged equipment and lost production.
- ✓ They are also known as surges or spikes.
- ✓ Transient over voltages can be classified as
 - Impulsive transient
 - Oscillatory transient
- ✓ A transient is a natural part of the process by which the power system moves from one steady state to another.
- ✓ Its duration is in the range of microseconds to milliseconds.
- ✓ Low frequency transients are caused by network switching.
- ✓ High frequency transients are caused by lightning and by inductive loads turning off.
- ✓ Surge suppressors are devices that conduct across the power line when some voltage threshold is exceeded.
- ✓ Typically they are used to absorb the energy in high frequency transients.
- ✓ The devices are used for over voltage protection is,
 - Surge arrester(crowbar & clamping device)
 - Transient over voltage Surge suppresser
 - Isolation transformer
 - Low pass filter
 - Low impedance power conditioners

- Pre-insertion resistors (transmission and distribution)
- Pre-insertion inductors (transmission)
- Synchronous closing (transmission and distribution)

Classification of transient over voltages:

Transient over voltages can be classified into two broad categories:

- Impulsive transient
- Oscillatory transient

Impulsive transient:

- ✓ An impulsive transient is a sudden non power frequency change in the steady state condition of the voltage or current waveforms that is essentially in one direction either positive or negative with respect to those waveforms.

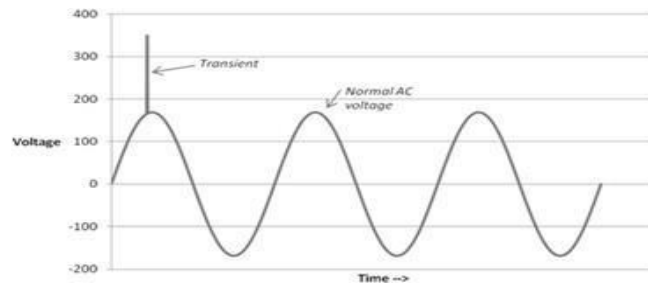

Oscillatory transient:

- ✓ A sudden, non power frequency change in the steady state condition of voltage or current that is bidirectional in polarity.
- ✓ An oscillatory transient is a sudden non power frequency change in the steady state condition of the voltage or current waveforms that is essentially in both directions positive and negative with respect to those waveforms.

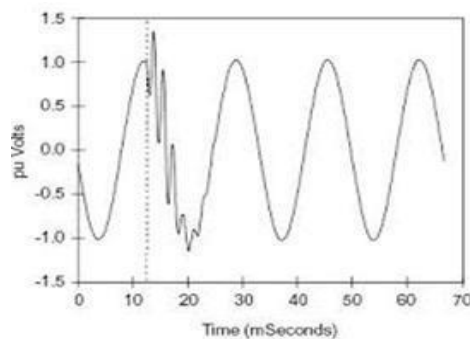

Sources of over voltages:

- ✓ Some of the causes of transient over voltages on power systems are,
 - Lightning – either direct strokes or by induction from nearby strokes.
 - Switching surges
 - Switching of utility capacitor banks
 - Phase to ground arcing
 - Resonance and Ferro resonance conditions on long or lightly loaded circuits.

Over voltages due to Lightning:

- ✓ Lightning is an electrical discharge in the air between clouds between clouds, between different charge centre within the same cloud, or between cloud and earth.
- ✓ Even through more discharges occur between or within clouds, there are enough strokes that terminate on the earth to cause problems to power systems and sensitive electronic equipment.

Over voltages due to Network switching:

- ✓ Switching operations within the distribution network are a major cause of oscillatory transient over voltages.
- ✓ Such operations include switching of utility capacitor banks,
- ✓ Switching of circuit breakers to clear network faults and
- ✓ Switching of distribution feeders.

3.3.2.1 Utility capacitor switching:

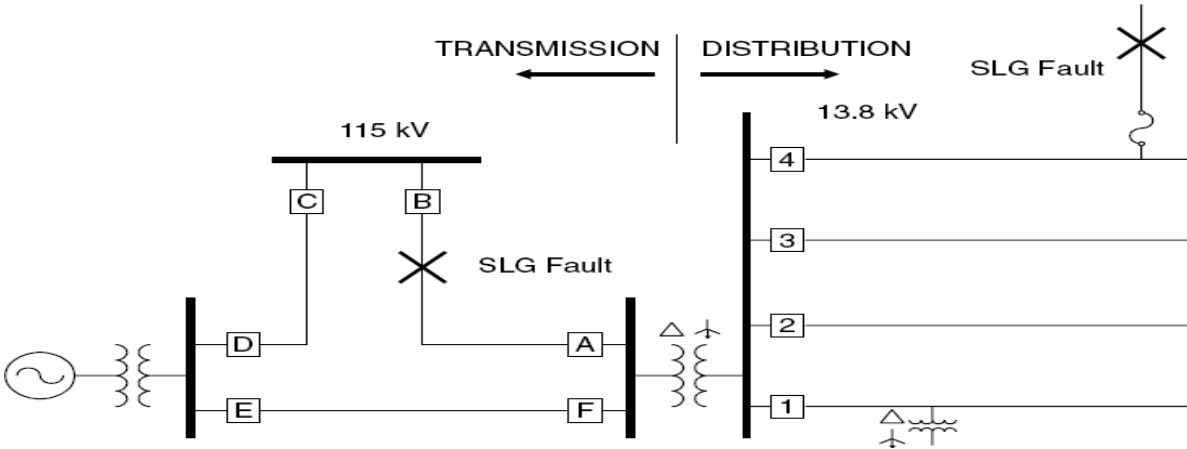

This is one of the most common switching events on utility systems; it is one of the main causes of oscillatory transients. This transient can propagate into the utility's local power system, pass through its distribution transformer, and enter into the end user's load facilities. A common symptom that directly relates to utility capacitor switching over voltages is that the resulting oscillatory transients appear at nearly identical times each day. This is because electric utilities, in anticipation of an increase in load, frequently switch their capacitors by time clock.

Ferro Resonance:

Ferro resonance is a special case of series LC resonance where the inductance involved is nonlinear and it is usually related to equipment with iron cores. It occurs when line capacitance resonates with the magnetizing reactance of a core while it goes in and out of saturation.

Ferro resonance is a general term applied to a wide variety of interactions between capacitors and iron core inductors that result in unusual voltages and or currents. In linear circuits, resonance occurs when the capacitive reactance equals the inductive reactance at the frequency at which the circuit is driven.

Iron core inductors have non linear characteristics and have a range of inductance values. Therefore, there may not be a case where the inductive reactance is equal to the capacitive reactance, but yet very high and damaging overvoltage occurs.

In power system the ferro resonance occurs when a non linear inductor is fed from a series capacitor. The non linear inductor in power system can be due to,

- ✓ The magnetic core of a wound type voltage transformer
- ✓ Bank type transformer
- ✓ The complex structure of a 3 limb three phase transformer.
- ✓ The complex structure of a 5 limb three phase power transformer.

The circuit capacitance in power system can be due to a number of elements.

Such as,

- ✓ The circuit to circuit capacitance
- ✓ Parallel lines capacitance
- ✓ Conductor to earth capacitance
- ✓ Circuit breaker grading capacitance

Mitigation of voltage swells:

Over voltages are extremely transient phenomena occurring for only fractions of a second, but which can never less have a negative effect on electronic equipment and can even result in their total failure. The total losses are due not only to the hardware damage and resultant repair costs, but above all to the major consequential costs due to stoppages in health facilities offices and production plants.

Although damage due to over voltage primarily occurs in industry and large community and office complexes, the losses suffered in the private sector due to damaged video, TV equipment and personal computers have also reached considerable levels. Over voltage protection units such as surge arresters and other protective systems can be installed at low cost in relation to the potential losses, so it makes economic sense to install such equipment.

The basic principles of over voltage protection of load equipments are:

- ✓ Limit the voltage across sensitive insulation
- ✓ Divert the surge current away from the load
- ✓ Block the surge current entering into the load
- ✓ Bonding of equipment with ground
- ✓ Prevent surge current flowing between grounds
- ✓ Design a low pass filter using limiting and blocking principle.

Surge Arresters and Surge Suppressors:

A surge arrester is a protective device for limiting surge voltages on equipment by discharging or bypassing surge current. Surge arrester allows only minimal flow of the 50 Hz/60Hz power current to ground. After the high frequency lightning surge current has been discharged. A surge arrester correctly applied will be capable of repeating its protective function until another surge voltage must be discharged.

There are several types of lightning arresters in general use. They differ only in constructional details but operate on the same principle, providing low resistance path for the surges to the round.

Rod arrester

Horn gap arrester

Multi gap arrester

Expulsion type lightning arrester

3.4.1.1 Rod gap arrester

It is a very simple type of diverter and consists of two 1.5 cm rods, which are bent at right angles with a gap in between as shown in Fig. One rod is connected to the line circuit and the other rod is connected to earth. The distance between gap and insulator (i.e. distance **P**) must not be less than one third of the gap length so that the arc may not reach the insulator and damage it.

Generally, the gap length is so adjusted that breakdown should occur at 80% of spark-voltage in order to avoid cascading of very steep wave fronts across the **insulators**.

The string of insulators for an **overhead line** on the bushing of transformer has frequently a rod gap across it. Fig 8 shows the rod gap across the bushing of a transformer. Under normal operating conditions, the gap remains non-conducting. On the occurrence of a high voltage surge on the line, the gap sparks over and the surge current is conducted to earth. In this way excess charge on the line due to the surge is harmlessly conducted to earth

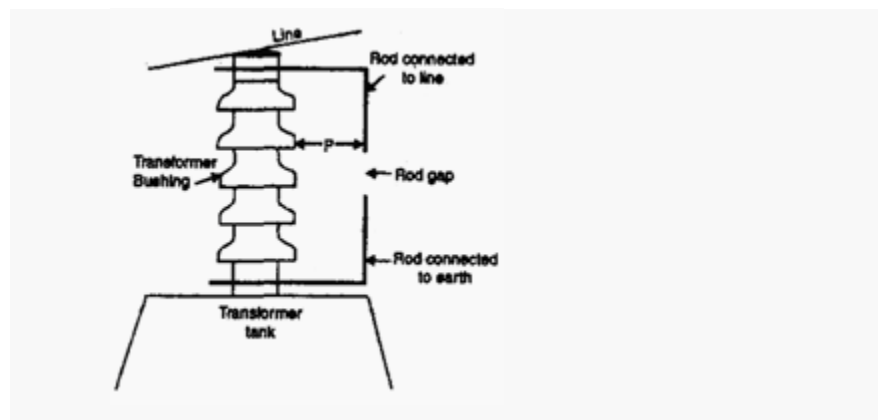

Typical rod gap arrester

3.4.1.2 Horn gap arrester

Fig shows the **horn gap arrester**. It consists of a horn shaped metal rods A and B separated by a small air gap. The horns are so constructed that distance between them gradually increases towards the top as shown. The horns are mounted on porcelain insulators. One end of horn is connected to the line through a resistance and choke coil L while the other end is effectively grounded.

The resistance **R** helps in limiting the follow current to a small value. The choke coil is so designed that it offers small reactance at normal power frequency but a very high reactance at transient frequency. Thus the choke does not allow the transients to enter the apparatus to be protected.

The gap between the horns is so adjusted that normal supply voltage is not enough to cause an arc across the gap.

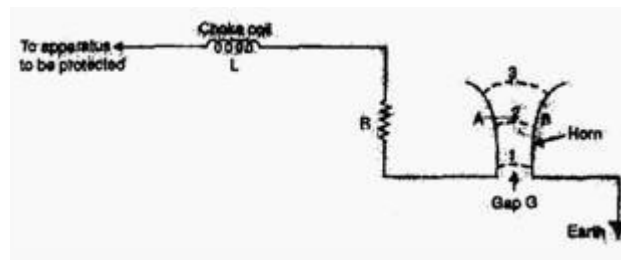

Under normal conditions, the gap is non-conducting i.e. normal supply voltage is insufficient to initiate the arc between the gap. On the occurrence of an over voltage, spark-over takes place across the small **gap G**. The heated air around the arc and the magnetic effect of the arc cause the arc to travel up the gap. The arc moves progressively into positions 1, 2 and 3.

At some position of the arc (position 3), the distance may be too great for the voltage to maintain the arc; consequently, the arc is extinguished. The excess charge on the line is thus conducted through the arrester to the ground.

3.4.1.3 Multi gap arrester

Fig shows the **multi gap arrester**. It consists of a series of metallic (generally alloy of zinc) cylinders insulated from one another and separated by small intervals of air gaps. The first cylinder (i.e. A) in the series is connected to the line and the others to the ground through a series resistance. The series resistance limits the power arc. By the inclusion of series resistance, the degree of protection against traveling waves is reduced.

In order to overcome this difficulty, some of the gaps (B to C in Fig) are shunted by resistance. Under normal conditions, the point B is at earth potential and the normal supply voltage is unable to break down the series gaps. On the occurrence an over voltage, the breakdown of series gaps A to B occurs.

The heavy current after breakdown will choose the straight – through path to earth via the shunted gaps B and C, instead of the alternative path through the shunt resistance.

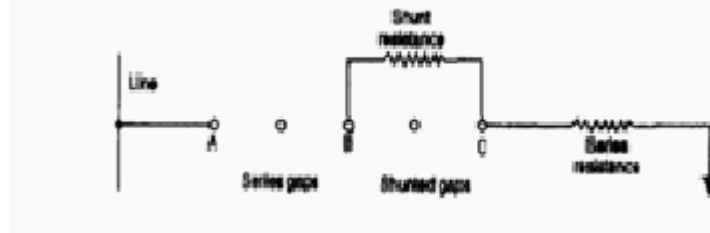

Typical multigap arrester

3.4.1.4 Expulsion type arrester

This type of arrester is also called '**protector tube**' and is commonly used on system operating at voltages up to 33kV. Fig shows the essential parts of an **expulsion type lightning arrester**.

It essentially consists of a rod gap AA' in series with a second gap enclosed within the fiber tube. The gap in the fiber tube is formed by two electrodes. The upper electrode is connected to rod gap and the lower electrode to the earth. One expulsion arrester is placed under each line conductor.

Fig shows the installation of expulsion arrester on an overhead line.

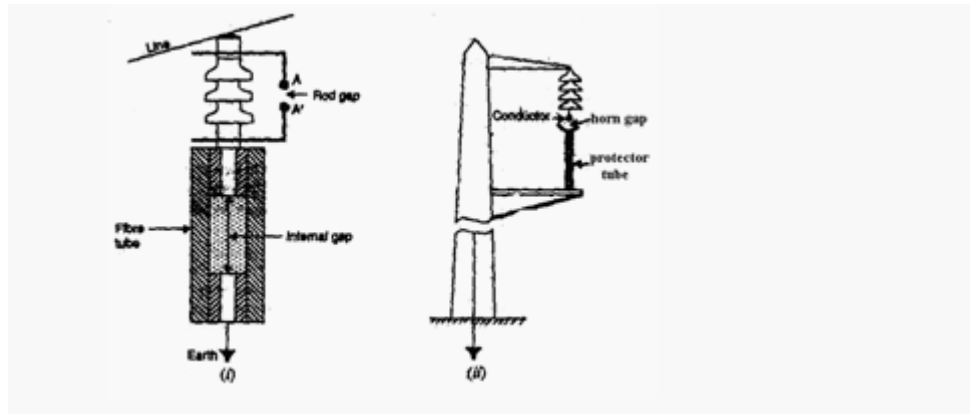

Typical expulsion arrester

On the occurrence of an over voltage on the line, the series gap AA' spanned and an arc is struck between the electrodes in the tube. The heat of the arc vaporizes some of the fiber of tube walls resulting in the production of neutral gas. In an extremely short time, the gas builds up high pressure and is expelled through the lower electrode, which is hollow. As the gas leaves the tube violently it carries away ionized air around the arc..

3.4.1.5 Valve type arrester

Valve type arresters incorporate non linear resistors and are extensively used on systems, operating at high voltages. Fig shows the various parts of a valve type arrester. It consists of two assemblies (i) series spark gaps and (ii) non-linear resistor discs in series. The non-linear elements are connected in series with the spark gaps. Both the assemblies are accommodated in tight porcelain container.

The spark gap is a multiple assembly consisting of a number of identical spark gaps in series. Each gap consists of two electrodes with fixed gap spacing. The voltage distribution across the gap is line raised by means of additional resistance elements called grading resistors across the gap. The spacing of the series gaps is such that it will withstand the normal circuit voltage. However an over voltage will cause the gap to break down causing the surge current to ground via the non-linear resistors.

The non-linear resistor discs are made of inorganic compound such as thyrite or metrosil. These discs are connected in series. The non-linear resistors have the

property of offering a high resistance to current flow when normal system voltage is applied, but a low resistance to the flow of high surge currents. In other words, the resistance of these non-linear elements decreases with the increase in current through them and vice-versa.

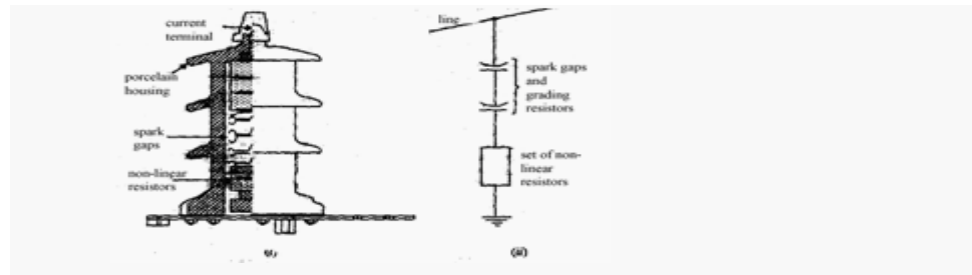

Non-linear resistor discs

Under normal conditions, the normal system voltage is insufficient to cause the breakdown of air gap assembly. On the occurrence of an over voltage, the breakdown of the series spark gap takes place and the surge current is conducted to earth via the non-linear resistors. Since the magnitude of surge current is very large, the non-linear elements will offer a very low resistance to the passage of surge. The result is that the surge will rapidly go to earth instead of being sent back over the line. When the surge is over, the non-linear resistors assume high resistance to stop the flow of current.

Low pass filter:

Low pass filters are composed of series inductors and parallel capacitors in general electric circuits. This LC combination provides a low impedance path to ground for selected resonant frequencies. Low pass filters employ CLC to achieve better protection even for high frequency transients. In surge protection usage, voltage clamping devices are added in parallel to the capacitors.

A low-pass filter is a filter that passes signals with a frequency lower than a certain cutoff frequency and attenuates signals with frequencies higher than the cutoff frequency. The amount of attenuation for each frequency depends on the filter design. The filter is sometimes called a high-cut filter, or treble cut filter in audio applications. A low-pass filter is the opposite of a high-pass filter. A band-pass filter is a combination of a low-pass and a high-pass filter.

Low-pass filters exist in many different forms, including electronic circuits used in audio, anti-aliasing filters for conditioning signals prior to analog-to-digital conversion, digital filters for smoothing sets of data, acoustic barriers, blurring of images, and so on. The moving average operation used in fields such as finance is a particular kind of low-pass filter, and can be analyzed with the same signal processing techniques as are used for other low-pass filters.

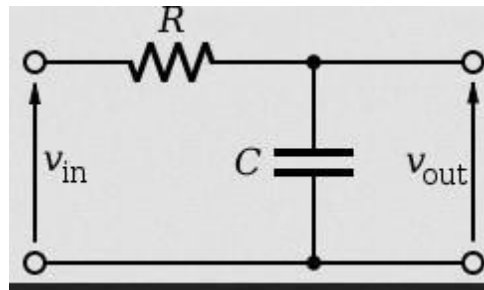

Power Conditioners:

Low impedance power conditioners are used primarily to interface with the switch mode power supplies found in electronic equipment. Low impedance power conditioners differ from isolation transformer in that this conditioner have much lower impedance and have a filter. The filter is on the output side and protects against high frequency noise and impulses. Normally the neutral to ground connection can be made on load side because of the existence of an isolation transformer. However, low to medium frequency transients can cause problems for power conditioners.

Lightning Protection:

Lighting is an electrical discharge in the air between clouds between clouds, between different charge centre within the same cloud, or between cloud and earth. Even through more discharges occur between or within clouds, there are enough strokes that terminate on the earth to cause problems to power systems and sensitive electronic equipment.

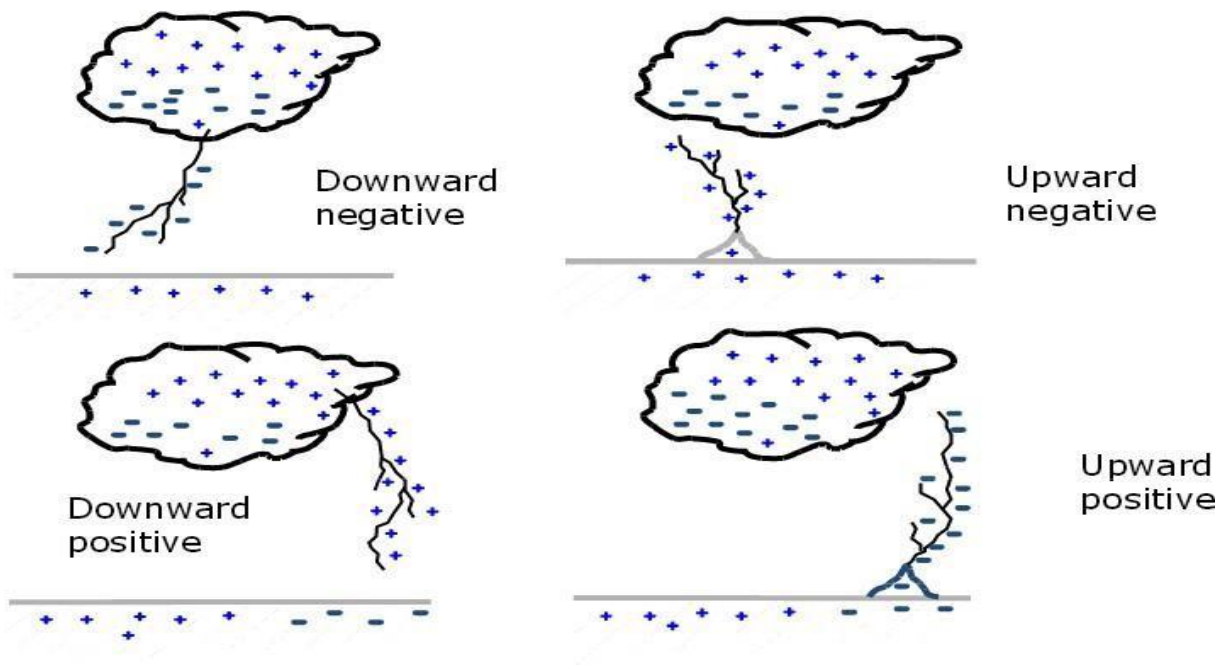

Lightning protection methods are

- ✓ Shielding and surge arresters
- ✓ Transmission line arresters

Shielding and surge arresters:

Shield wire and surge arresters play a significant role for protecting overhead distribution lines. The line with shield wire can reduce the number of flashovers in open ground and number of flashovers than shield wire. The application of surge arresters provides better performance than shield wire.

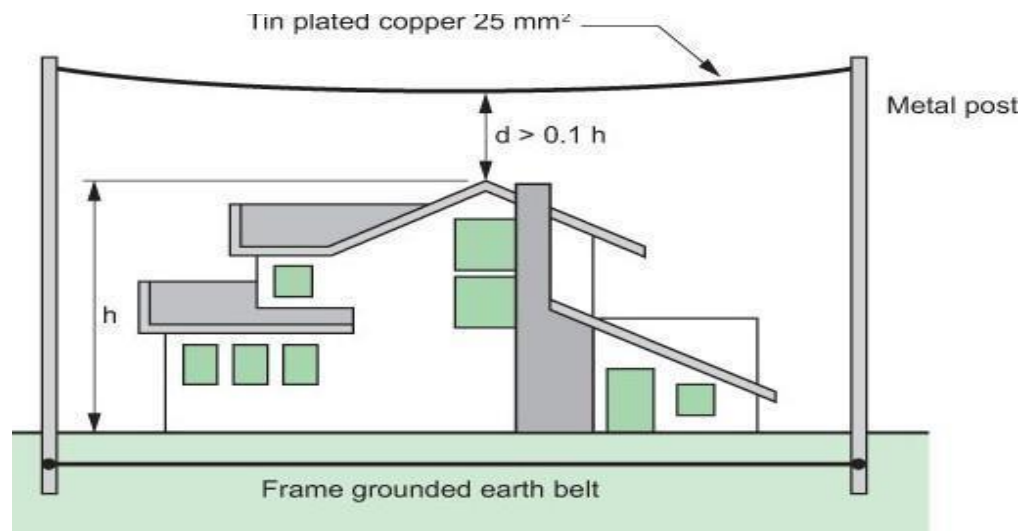

Provides both shielding and Surge arresters:

- ✓ Minimize the possibility of direct lightning strike to bus and major equipments in the substation and hence the outage and possible failure of major electrical equipment.
- ✓ Shielding may allow some smaller strokes to strike the bus work and equipment. Even though these strokes may not cause flash over they may damage internal insulation systems of transformer, etc... unless they have proper surge arresters mounted at their terminals.
- ✓ Surge arresters will provide coordinated protection from lightning and switching surges.

Protection of Transformers:

There are different kinds of transformers such as two winding or three winding electrical power transformers, auto transformer, regulating transformers, earthing transformers, rectifier transformers etc. Different transformers demand different schemes of transformer protection depending upon their importance, winding connections, earthing methods and mode of operation etc.

It is common practice to provide Buchholz relay protection to all 0.5 MVA and above transformers. While for all small size distribution transformers, only high voltage fuses are used as main protective device. For all larger rated and important distribution transformers, over current protection along with restricted earth fault protection is applied. Differential protection should be provided in the transformers rated above 5 MVA.

Nature of Transformer Faults:

A transformer generally suffers from following types of transformer fault-

- ✓ Over current due to overloads and external short circuits,
- ✓ Terminal faults,
- ✓ Winding faults,
- ✓ Incipient faults.

Generally **Differential protection** is provided in the electrical power transformer rated more than 5 MVA.

The **Differential Protection of Transformer** has many advantages over other schemes of protection.

- 1) The faults occur in the transformer inside the insulating oil can be detected by Buchholz relay. But if any fault occurs in the transformer but not in oil then it can not be detected by Buchholz relay. Any flash over at the bushings are not adequately covered by Buchholz relay. **Differential relays** can detect such type of faults. Moreover Buchholz relay is provided in transformer for detecting any internal fault in the transformer but Differential Protection scheme detects the same in more faster way.
- 2) The **differential relays** normally response to those faults which occur in side the differential protection zone of transformer.

Differential Protection Scheme:

Principle of **Differential Protection** scheme is one simple conceptual technique. The differential relay actually compares between primary current and secondary current of power transformer, if any unbalance found in between primary and secondary currents the relay will actuate and inter trip both the primary and secondary circuit breaker of the transformer.

Suppose you have one transformer which has primary rated current I_p and secondary current I_s . If you install CT of ratio $I_p/1A$ at primary side and similarly, CT of ratio $I_s/1A$ at secondary side of the transformer. The secondaries of these both CTs are connected together in such a manner that secondary currents of both CTs will oppose each other. In other words, the secondary's of both CTs should be connected to same current coil of differential relay in such a opposite manner that there will be no resultant current in that coil in normal working condition of the transformer. But if any major fault occurs inside the transformer due to which the normal ratio of the transformer disturbed then the secondary current of both transformer will not remain the same and one resultant current will flow through the current coil of the differential relay, which will actuate the relay and inter trip both the primary and secondary circuit breakers. To correct phase shift of current because of star - delta connection of transformer winding in case of three phase transformer, the current transformer secondary's should be connected in delta.

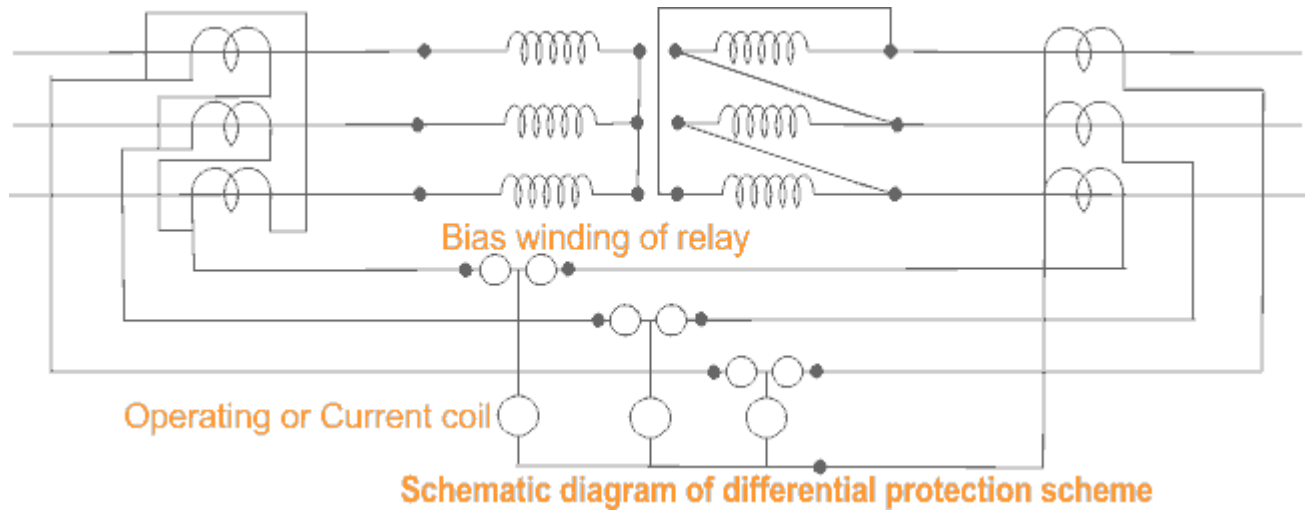

Protection of cables

A **cable** is two or more wires running side by side and bonded, twisted, or braided together to form a single assembly. The term originally referred to a nautical line of specific length where multiple ropes, each laid clockwise, are then laid together anti-clockwise and shackled to produce a strong thick line, resistant to water absorption, that was used to anchor large ships.

In mechanics, cables, otherwise known as wire ropes, are used for lifting, hauling, and towing or conveying force through tension. In electrical engineering cables are used to carry electric currents. An optical cable contains one or more optical fibers in a protective jacket that supports the fibers.

In building construction, electrical cable jacket material is a potential source of fuel for fires. To limit the spread of fire along cable jacketing, one may use cable coating materials or one may use cables with jacketing that is inherently fire retardant. The plastic covering on some metal clad cables may be stripped off at installation to reduce the fuel source for fires.

Inorganic coatings and boxes around cables safeguard the adjacent areas from the fire threat associated with unprotected cable jacketing. However, this fire protection also traps heat generated from conductor losses, so the protection must be thin. To provide fire protection to a cable, the insulation is treated with fire retardant materials, or non-combustible mineral insulation is used (MICC cables).

Computer Analysis Tools for Transient – PSCAD and EMTP

The following computational tools are used in general to solve different electrical network problems:

- ✓ Digital Computers
- ✓ Analog Computers
- ✓ Transient electrical network analyzers
- ✓ Special purpose simulators such as HVDC simulator

The types of studies usually conducted are as follows:

- ✓ Power flow studies
- ✓ Dynamic Simulation
- ✓ Control System parameter optimization studies
- ✓ Harmonic studies
- ✓ Switching transient studies

Digital Computers:

Digital computers are the most versatile and can be used to solve all the earlier mentioned problems, although in particular cases and depending on the facilities available, other methods can be more advantages and economical. As very large and fast digital computers are available today, invariably all large problems are solved using digital computers with commercial software packages or locally developed special purpose computer programs.

Analog Computers:

An analog computer is a form of computer that uses the continuously changeable aspects of physical phenomena such as electrical, mechanical, or hydraulic quantities to model the problem being solved. In contrast, digital computers represent varying quantities symbolically, as their numerical values change. As an analog computer does not use discrete values, but rather continuous values, processes cannot be reliably repeated with exact equivalence, as they can with Turing machines. Analog computers do not suffer from the quantization noise inherent in digital computers, but are limited instead by analog noise.

Analog computers were widely used in scientific and industrial applications where digital computers of the time lacked sufficient performance. Analog computers can have a very wide range of complexity. Slide rules and monographs are the simplest, while naval gunfire control computers and large hybrid digital/analog computers were among the most complicated.^[1] Systems for process control and protective relays used analog computation to perform control and protective functions.

Power System Computer Aided Design – PSCAD / EMTDC

PSCAD/EMTDC is a general-purpose time domain simulation program for multi-phase power systems and control networks. It is mainly dedicated to the study of transients in power systems. A full library of advanced components allows a user to precisely model interactions between electrical networks and loads in various configurations. A graphical user interface and numerous control tools make PSCAD a convenient and interactive tool for both analysis and design of any power system.

PSCAD seamlessly integrated visual environment features all aspects of conducting a simulation, including circuit assembly, run-time control, analysis and reporting. Users can easily interact with the components during the simulation because of the variety of control tools. The solution meters and the plotting traces are also visible and available during the simulation. Signals can be analyzed in real time.

PSCAD features a broad range of models for power system and power electronic studies such as:

- ✓ Frequency dependent transmission lines and cables,
- ✓ Transformers (classical model with saturation/Umec model)
- ✓ Various machines, (synchronous, asynchronous, DC)
- ✓ Various turbines (hydro, steam, wind),
- ✓ Converters & FACTS,
- ✓ Drive & control blocks,
- ✓ Relays.

Fast and Accurate

The time steps interpolation technique combines accuracy and quickness: it allows the simulation to precisely represent the commutations of breakers and switches in the electrical model, for any model's size, up to extremely large models. PSCAD results are solved as instantaneous values, and can be converted to phasor magnitudes and angles via built-in transducers and measurement functions such as true-rms meters or FFT spectrum analyzers. The PSCAD simulation tool can duplicate the response of a power system at any frequency, because the computation step chosen by the user can go from several nanoseconds to several seconds.

Optimization:

PSCAD features multi-run capabilities, enabling a user to run a case multiple times with a set of parameters changed each time in a predetermined manner. This facility makes optimization an easy game as the optimum results (according the criterion the users defines before) are highlighted by the software.

Customization:

Create custom components? PSCAD features the built-in Component Workshop, the tool used to create all the Master Library components. The look of the components and the data forms are all designed graphically. It allows each user to easily create their own component library.

Applications:

1. Power lines & cables
2. Large non-linear industrial loads
3. Transformers with saturation
4. Power electronic systems & drives
5. FACTS/HVDC systems
6. Protection relay coordination
7. Arc furnace flicker
8. Distributed power generation
9. Rotating machines
10. Embedded systems

EMTP:

EMTP is an acronym for Electro Magnetic Transients Program. It is usually part of a battery of software tools targeting a slice of the spectrum of design and operation problems presented by Electric Power Systems to the Electrical Engineer, that of the so-called "electromagnetic transients" and associated insulation issues.

Originating in the habilitation (postdoctoral) thesis of Dr. Hermann Dommel in Germany in the mid sixties, and brought up to its present robust and industry strength status by the cooperation of many professionals of power engineering led by the two champions: Dr. Dommel (currently with the University of British Columbia, in Vancouver, B.C., Canada), and Dr. Scott Meyer (from the Bonneville Power Administration in Portland, Oregon, U.S.A.). Both have been awarded the highest recognition that the Institute of Electric and Electronic Engineers (IEEE) grants to some of its members: they are both FIEEE (Fellows of the IEEE).

There are two basic streams of EMTP programs: "EMTP" as known such originates from the program development at BPA - an agency of the U.S. Department of Energy - and those written from scratch. The EMTP-ATP and MT-EMTP programs, for example, are based on the original BPA and DCG-EMTP versions.

Unit-4

Harmonics

Harmonic sources from commercial and industrial loads, locating harmonic sources. Power system response characteristics - Harmonics Vs transients. Effect of harmonics - harmonic distortion -voltage and current distortion - harmonic indices - inter harmonics – resonance. Harmonic distortion evaluation - devices for controlling harmonic distortion - passive and active filters. IEEE and IEC standards.

4.1. Introduction

Harmonic voltages and currents in an electric power system are a result of non-linear electric loads. Harmonic frequencies in the power grid are a frequent cause of power quality problems. Harmonics in power systems result in increased heating in the equipment and conductors, misfiring in variable speed drives, and torque pulsations in motors

A harmonic of a wave is a component frequency of the signal that is an integer multiple of the fundamental frequency, i.e. if the fundamental frequency is f , the harmonics have frequencies $2f, 3f, 4f, \dots$ etc. The harmonics have the property that they are all periodic at the fundamental frequency; therefore the sum of harmonics is also periodic at that frequency. Harmonic frequencies are equally spaced by the width of the fundamental frequency and can be found by repeatedly adding that frequency. For example, if the fundamental frequency (first harmonic) is 25 Hz, the frequencies of the next harmonics are: 50 Hz (2nd harmonic), 75 Hz (3rd harmonic), 100 Hz (4th harmonic) etc.

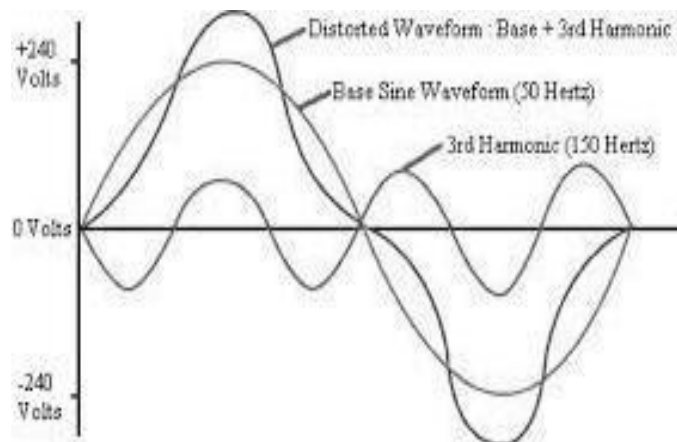

Harmonic Sources from Commercial Loads

Commercial facilities such as office complexes, department stores, hospitals, and Internet data centers are dominated with high-efficiency fluorescent lighting with electronic ballasts, adjustable-speed drives for the heating, ventilation, and air conditioning (HVAC) loads, elevator drives, and sensitive electronic equipment supplied by single-phase switch-mode power supplies. Commercial loads are characterized by a large number of small harmonic-producing loads. Depending on the diversity of the different load types, these small harmonic currents may add in phase or cancel each other. The voltage distortion levels depend on both the circuit impedances and the overall harmonic current distortion. Since power factor correction capacitors are not typically used in commercial facilities, the circuit impedance is dominated by the service entrance transformers and conductor impedances. Therefore, the voltage distortion can be estimated simply by multiplying the current by the impedance adjusted for frequency. Characteristics of typical nonlinear commercial loads are detailed in the following sections.

Single-phase power supplies

Electronic power converter loads with their capacity for producing harmonic currents now constitute the most important class of nonlinear loads in the power system. Advances in semiconductor device technology have fueled a revolution in power electronics over the past decade, and there is every indication that this trend will continue. Equipment includes adjustable-speed motor drives, electronic power supplies, dc motor drives, battery chargers, electronic ballasts, and many other rectifier and inverter applications.

A major concern in commercial buildings is that power supplies for single-phase electronic equipment will produce too much harmonic current for the wiring. DC power for modern electronic and microprocessor-based office equipment is commonly derived from single-phase full-wave diode bridge rectifiers. The percentage of load that contains electronic power supplies is increasing at a dramatic pace, with the increased utilization of personal computers in every commercial sector.

There are two common types of single-phase power supplies. Older technologies use ac-side voltage control methods, such as transformers, to reduce voltages to the level required for the dc bus. The inductance of the transformer provides a beneficial side effect by smoothing the input current waveform, reducing harmonic content. Newer-technology switch-mode power

supplies (see Fig. 4.5) use dc-to-dc conversion techniques to achieve a smooth dc output with small, lightweight components. The input diode bridge is directly connected to the ac line, eliminating the transformer. This results in a coarsely regulated dc voltage on the capacitor. This direct current is then converted back to alternating current at a very high frequency by the switcher and subsequently rectified again. Personal computers, printers, copiers, and most other single-phase electronic equipment now almost universally employ switch-mode power supplies. The key advantages are the light weight, compact size, efficient operation, and lack of need for a transformer. Switch-mode power supplies can usually tolerate large variations in input voltage.

Because there is no large ac-side inductance, the input current to the power supply comes in very short pulses as the capacitor $C1$ regains its charge on each half cycle. Figure 4.6 illustrates the current waveform and spectrum for an entire circuit supplying a variety of electronic equipment with switch-mode power supplies.

A distinctive characteristic of switch-mode power supplies is a very high third-harmonic content in the current. Since third-harmonic current components are additive in the neutral of a three-phase system, the increasing application of switch-mode power supplies causes concern for overloading of neutral conductors, especially in older buildings where an undersized neutral may have been installed. There is also a concern for transformer overheating due to a combination of harmonic content of the current, stray flux, and high neutral currents.

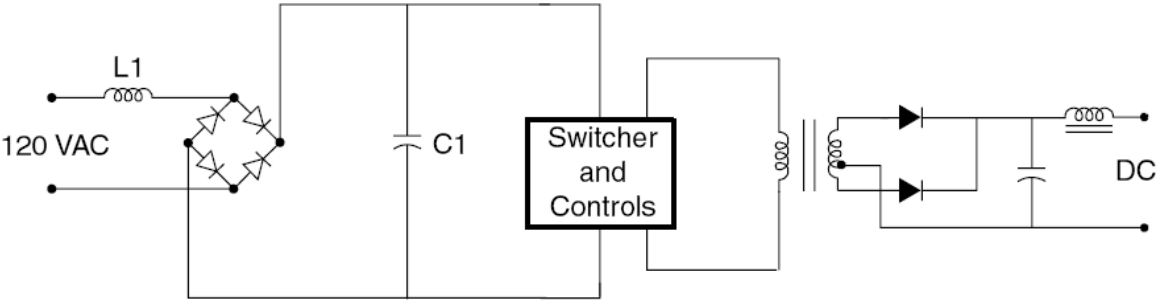

Figure 4.5 Switch-mode power supply.

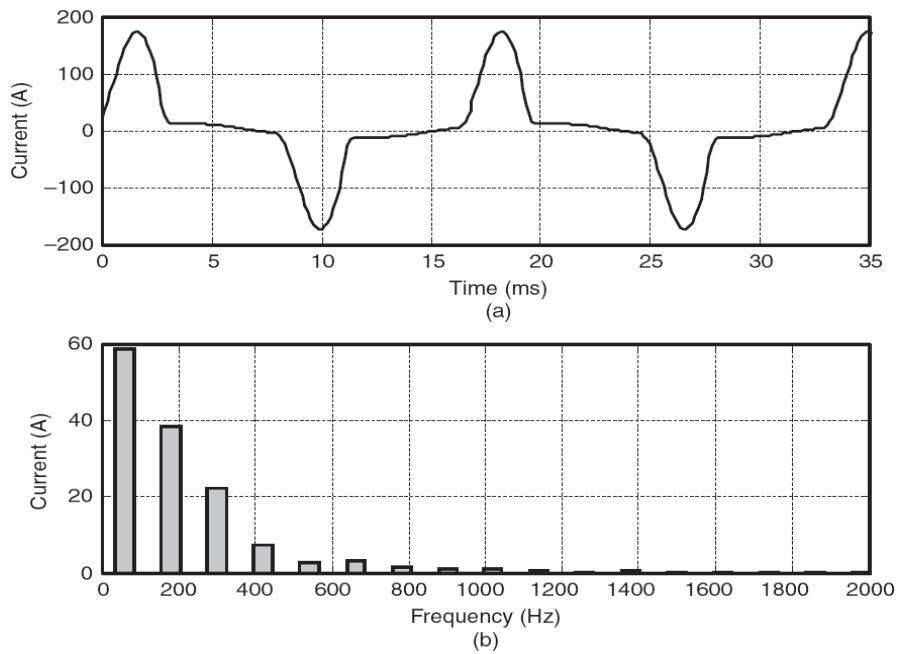

Figure 4.6 SMPS current and harmonic spectrum.

Fluorescent lighting

Lighting typically accounts for 40 to 60 percent of a commercial building load. According to the 1995 Commercial Buildings Energy Consumption study conducted by the U.S. Energy Information Administration, fluorescent lighting was used on 77 percent of commercial floor spaces, while only 14 percent of the spaces used incandescent lighting.¹ Fluorescent lights are a popular choice for energy savings.

Fluorescent lights are discharge lamps; thus they require a ballast to provide a high initial voltage to initiate the discharge for the electric current to flow between two electrodes in the fluorescent tube. Once the discharge is established, the voltage decreases as the arc current increases. It is essentially a short circuit between the two electrodes, and the ballast has to quickly reduce the current to a level to maintain the specified lumen output. Thus, a ballast is also a current-limiting device in lighting applications.

There are two types of ballasts, magnetic and electronic. A standard magnetic ballast is simply made up of an iron-core transformer with a capacitor encased in an insulating material. A single magnetic ballast can drive one or two fluorescent lamps, and it operates at the line

fundamental frequency, i.e., 50 or 60 Hz. The iron-core magnetic ballast contributes additional heat losses, which makes it inefficient compared to an electronic ballast.

An electronic ballast employs a switch-mode-type power supply to convert the incoming fundamental frequency voltage to a much higher frequency voltage typically in the range of 25 to 40 kHz. This high frequency has two advantages. First, a small inductor is sufficient to limit the arc current. Second, the high frequency eliminates or greatly reduces the 100- or 120-Hz flicker associated with an iron-core magnetic ballast.

Standard magnetic ballasts are usually rather benign sources of additional harmonics themselves since the main harmonic distortion comes from the behavior of the arc. Figure 4.7 shows a measured fluorescent lamp current and harmonic spectrum. The current THD is a moderate 15 percent. As a comparison, electronic ballasts, which employ switch-mode power supplies, can produce double or triple the standard magnetic ballast harmonic output. Figure 4.8 shows a fluorescent lamp with an electronic ballast that has a current THD of 144.

Other electronic ballasts have been specifically designed to minimize harmonics and may actually produce less harmonic distortion than the normal magnetic ballast-lamp combination. Electronic ballasts typically produce current THDs in the range of between 10 and 32 percent.

A current THD greater than 32 percent is considered excessive according to ANSI C82.11-1993, *High-Frequency Fluorescent Lamp Ballasts*. Most electronic ballasts are equipped with passive filtering to reduce the input current harmonic distortion to less than 20 percent.

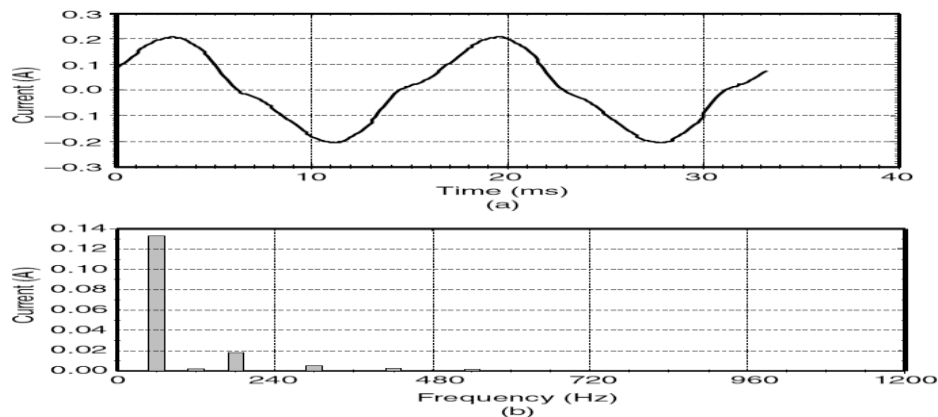

Figure 4.7 Fluorescent lamp with (a) magnetic ballast current waveform and (b) its harmonic spectrum.

Since fluorescent lamps are a significant source of harmonics in commercial buildings, they are usually distributed among the phases in a nearly balanced manner. With a delta-connected supply transformer, this reduces the amount of triplen harmonic currents flowing onto the power supply system.

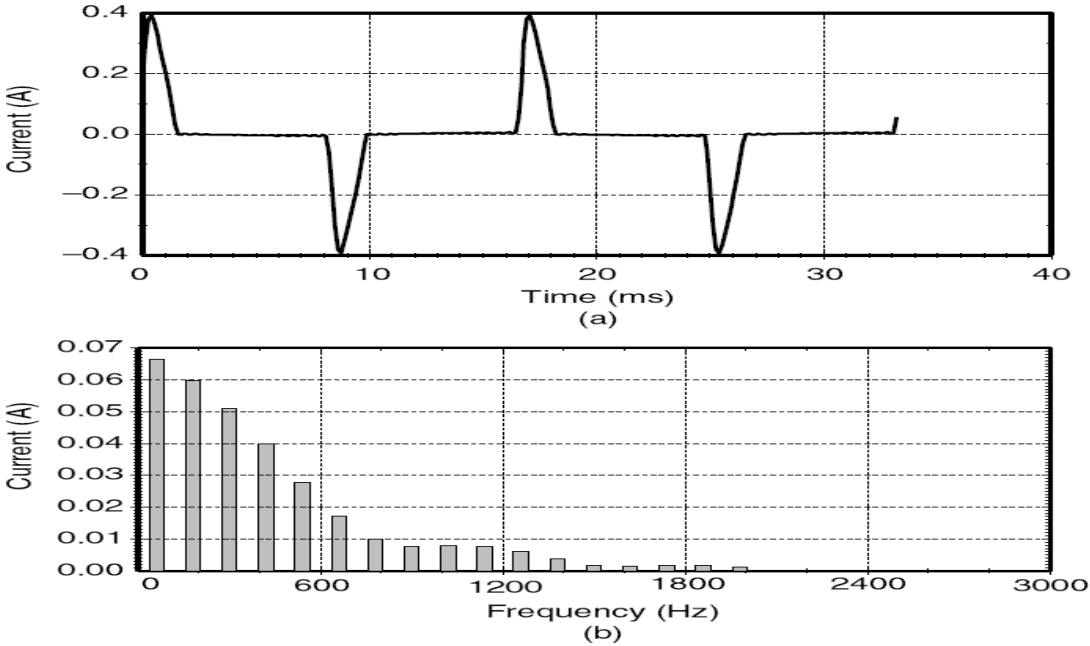

Figure 4.8 Fluorescent lamp with (a) electronic ballast current waveform and (b) its harmonic spectrum.

Adjustable-speed drives for HVAC and elevators

Common applications of adjustable-speed drives (ASDs) in commercial loads can be found in elevator motors and in pumps and fans in HVAC systems. An ASD consists of an electronic power converter that converts ac voltage and frequency into variable voltage and frequency. The variable voltage and frequency allows the ASD to control motor speed to match the application requirement such as slowing a pump or fan. ASDs also find many applications in industrial loads.

Harmonics sources from industrial loads:

Modern industrial facilities are characterized by the widespread application of nonlinear loads. These loads can make up a significant portion of the total facility loads and inject

harmonic currents into the power system, causing harmonic distortion in the voltage. This harmonic problem is compounded by the fact that these nonlinear loads have a relatively low power factor. Industrial facilities often utilize capacitor banks to improve the power factor to avoid penalty charges. The application of power factor correction capacitors can potentially magnify harmonic currents from the nonlinear loads, giving rise to resonance conditions within the facility. The highest voltage distortion level usually occurs at the facility's low-voltage bus where the capacitors are applied. Resonance conditions cause motor and transformer overheating, and misoperation of sensitive electronic equipment.

Nonlinear industrial loads can generally be grouped into three categories: three-phase power converters, arcing devices, and saturable devices. Sections 4.6.1 to 4.6.3 detail the industrial load characteristics.

Three-phase power converters

Three-phase electronic power converters differ from single-phase converters mainly because they do not generate third-harmonic currents. This is a great advantage because the third-harmonic current is the largest component of harmonics. However, they can still be significant sources of harmonics at their characteristic frequencies, as shown in Fig. 4.9. This is a typical current source type of adjustable-speed drive. The harmonic spectrum given in Fig. 4.9 would also be typical of a dc motor drive input current. Voltage source inverter drives (such as PWM-type drives) can have much higher distortion levels as shown in Fig. 4.10.

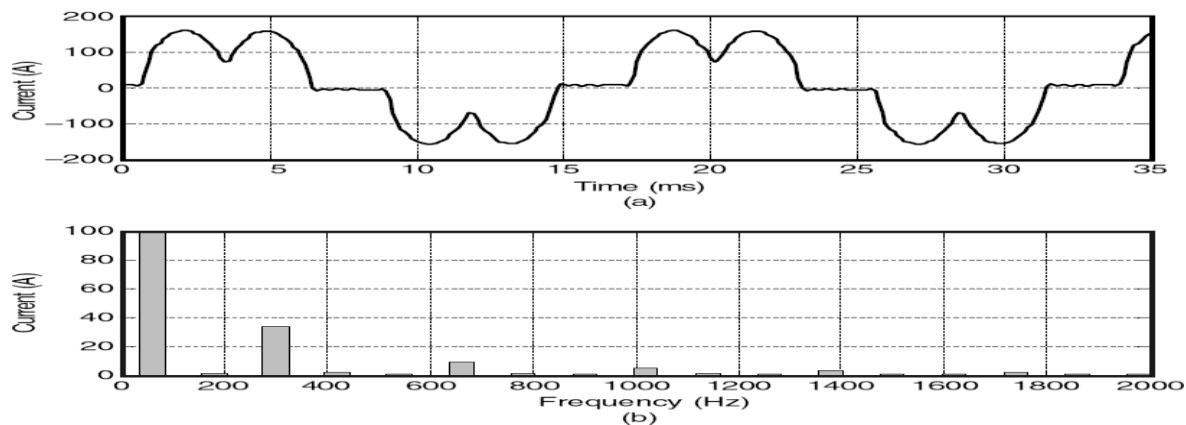

Figure 4.9 Current and harmonic spectrum for CSI-type ASD.

The input to the PWM drive is generally designed like a three-phase version of the switch-mode power supply in computers. The rectifier feeds directly from the ac bus to a large capacitor on the dc bus. With little intentional inductance, the capacitor is charged in very short pulses, creating the distinctive “rabbit ear” ac-side current waveform with very high distortion. Whereas the switch-mode power supplies are generally for very small loads, PWM drives are now being applied for loads up to 500 horsepower (hp). This is a justifiable cause for concern from power engineers.

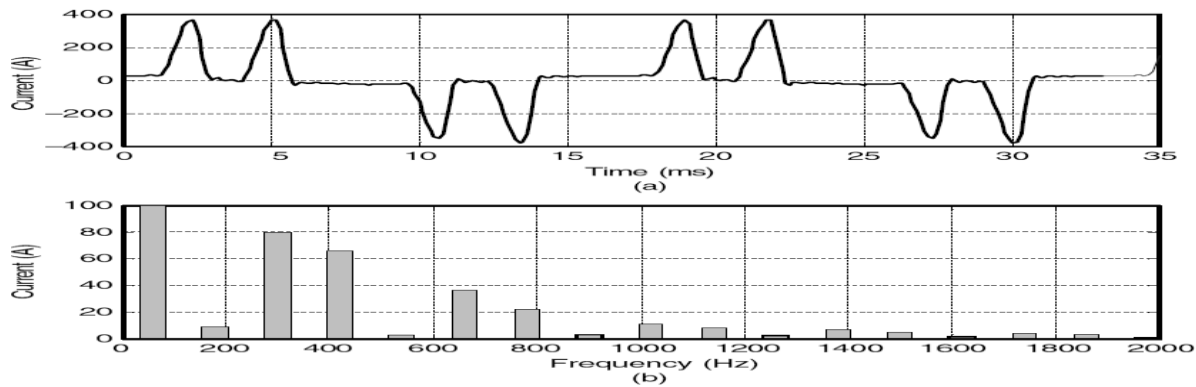

Figure 4.10 Current and harmonic spectrum for PWM-type ASD.

DC drives. Rectification is the only step required for dc drives. Therefore, they have the advantage of relatively simple control systems. Compared with ac drive systems, the dc drive offers a wider speed range and higher starting torque. However, purchase and maintenance costs for dc motors are high, while the cost of power electronic devices has been dropping year after year. Thus, economic considerations limit use of the dc drive to applications that require the speed and torque characteristics of the dc motor.

Most dc drives use the six-pulse rectifier shown in Fig. 4.11. Large drives may employ a 12-pulse rectifier. This reduces thyristor current duties and reduces some of the larger ac current harmonics. The two largest harmonic currents for the six-pulse drive are the fifth and seventh.

They are also the most troublesome in terms of system response. A 12-pulse rectifier in this application can be expected to eliminate about 90 percent of the fifth and seventh harmonics, depending on system imbalances. The disadvantages of the 12-pulse drive are that there is more cost in electronics and another transformer is generally required.

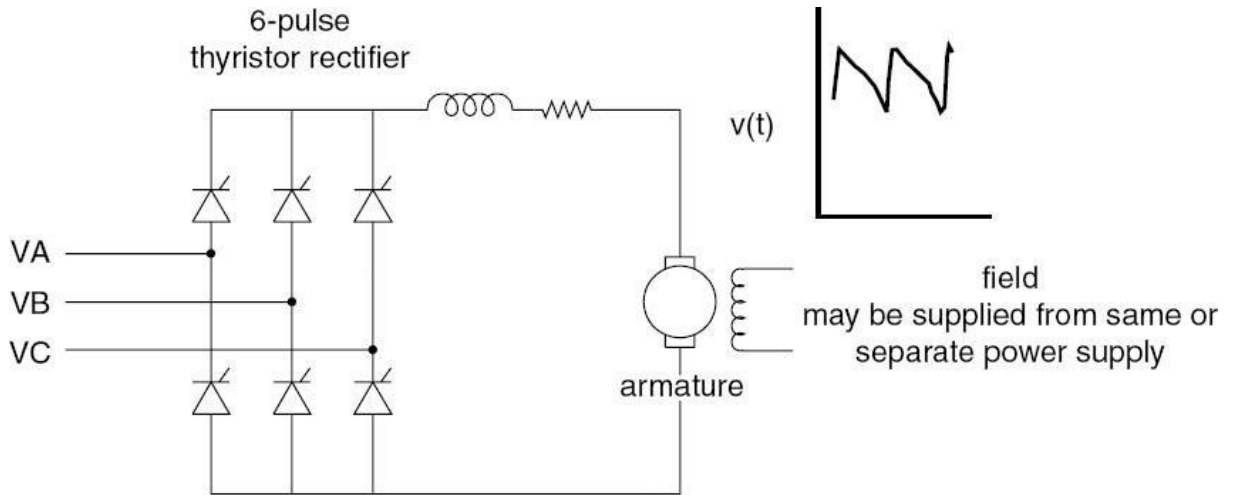

Figure 4.11 Six-pulse dc ASD.

AC drives. In ac drives, the rectifier output is inverted to produce a variable-frequency ac voltage for the motor. Inverters are classified as voltage source inverters (VSIs) or current source inverters (CSIs). A VSI requires a constant dc (i.e., low-ripple) voltage input to the inverter stage. This is achieved with a capacitor or *LC* filter in the dc link. The CSI requires a constant current input; hence, a series inductor is placed in the dc link.

AC drives generally use standard squirrel cage induction motors. These motors are rugged, relatively low in cost, and require little maintenance. Synchronous motors are used where precise speed control is critical.

A popular ac drive configuration uses a VSI employing PWM techniques to synthesize an ac waveform as a train of variable-width dc pulses (see Fig. 4.11). The inverter uses either SCRs, gate turnoff (GTO) thyristors, or power transistors for this purpose. Currently, the VSI PWM drive offers the best energy efficiency for applications over a wide speed range for drives up through at least 500 hp. Another advantage of PWM drives is that, unlike other types of drives, it is not necessary to vary rectifier output voltage to control motor speed. This allows the rectifier thyristors to be replaced with diodes, and the thyristor control circuitry to be eliminated.

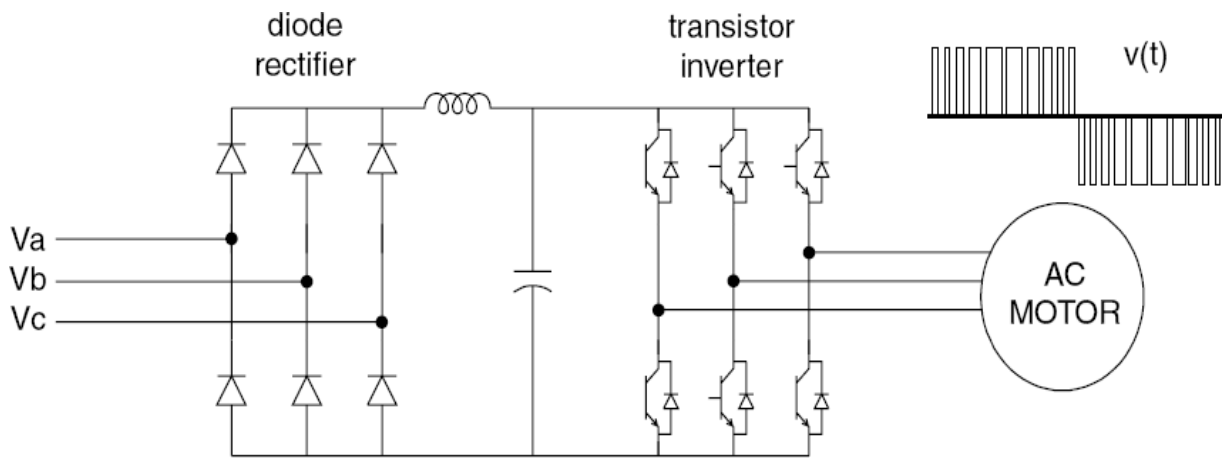

Figure 4.11 PWM ASD.

Very high power drives employ SCRs and inverters. These may be 6-pulse, as shown in Fig. 4.12, or like large dc drives, 12-pulse. VSI drives (Fig. 4.12a) are limited to applications that do not require rapid changes in speed. CSI drives (Fig. 4.12b) have good acceleration/deceleration characteristics but require a motor with a leading power factor (synchronous or induction with capacitors) or added control circuitry to commute the inverter thyristors. In either case, the CSI drive must be designed for use with a specific motor. Thyristors in current source inverters must be protected against inductive voltage spikes, which increases the cost of this type of drive.

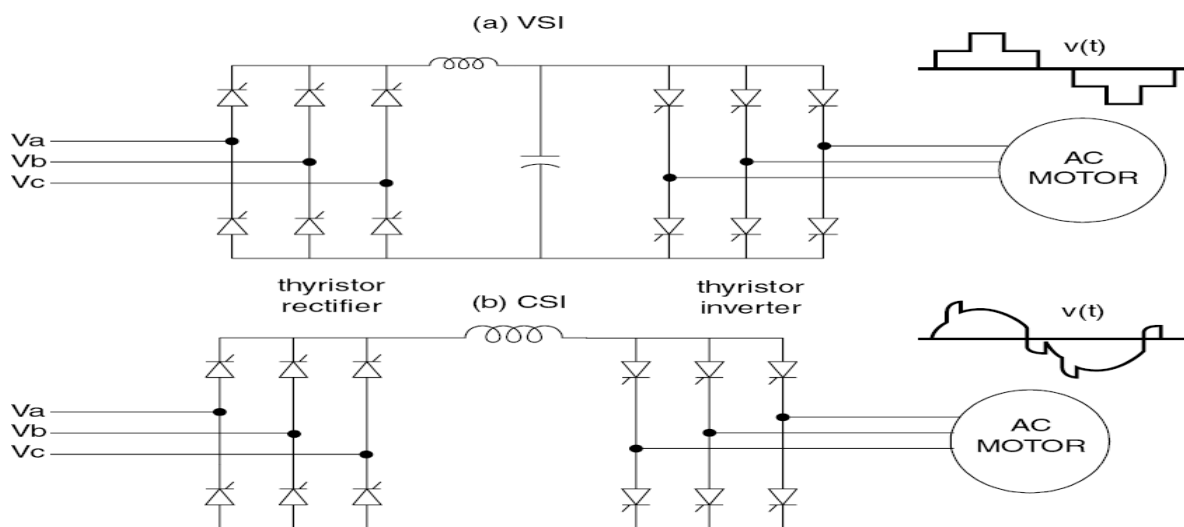

Figure 4.12 Large ac ASDs.

Impact of operating condition. The harmonic current distortion in adjustable-speed drives is not constant. The waveform changes significantly for different speed and torque values. Figure

4.13 shows two operating conditions for a PWM adjustable-speed drive. While the waveform at 42 percent speed is much more distorted proportionately, the drive injects considerably higher magnitude harmonic currents at rated speed. The bar chart shows the amount of current injected. This will be the limiting design factor, not the highest THD. Engineers should be careful to understand the basis of data and measurements concerning these drives before making design decisions

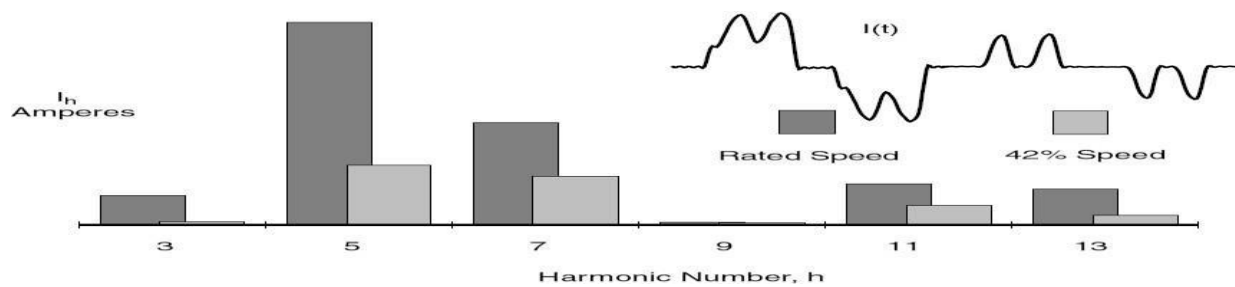

Figure 4.13 Effect of PWM ASD speed on ac current harmonics.

Arcing devices

This category includes arc furnaces, arc welders, and discharge-type lighting (fluorescent, sodium vapor, mercury vapor) with magnetic

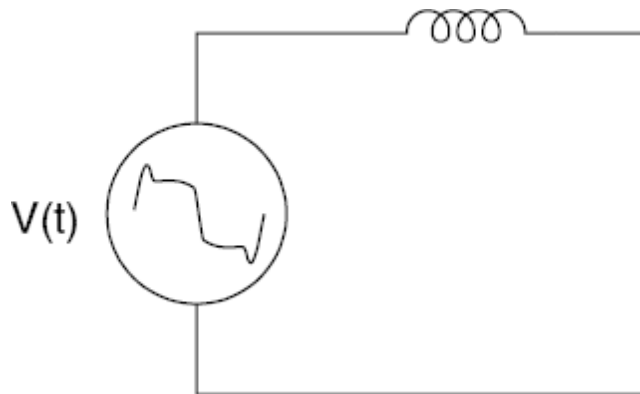

Figure 4.14 Equivalent circuit for an arcing device.

(rather than electronic) ballasts. As shown in Fig. 4.14, the arc is basically a voltage clamp in series with a reactance that limits current to a reasonable value.

The voltage-current characteristics of electric arcs are nonlinear. Following arc ignition, the voltage decreases as the arc current increases, limited only by the impedance of the power system. This gives the arc the appearance of having a negative resistance for a portion of its operating cycle such as in fluorescent lighting applications.

In electric arc furnace applications, the limiting impedance is primarily the furnace cable and leads with some contribution from the power system and furnace transformer. Currents in excess of 60,000 A are common.

The electric arc itself is actually best represented as a source of voltage harmonics. If a probe were to be placed directly across the arc, one would observe a somewhat trapezoidal waveform. Its magnitude is largely a function of the length of the arc. However, the impedance of ballasts or furnace leads acts as a buffer so that the supply voltage is only moderately distorted. The arcing load thus appears to be a relatively stable harmonic current source, which is adequate for most analyses. The exception occurs when the system is near resonance and a Thevenin equivalent model using the arc voltage waveform gives more realistic answers.

Saturable devices

Equipment in this category includes transformers and other electromagnetic devices with a steel core, including motors. Harmonics are generated due to the nonlinear magnetizing characteristics of the steel (see Fig. 4.15).

Power transformers are designed to normally operate just below the “knee” point of the magnetizing saturation characteristic. The operating flux density of a transformer is selected based on a complicated optimization of steel cost, no-load losses, noise, and numerous other factors. Many electric utilities will penalize transformer vendors by various amounts for no-load and load losses, and the vendor will try to meet the specification with a transformer that has the lowest evaluated cost. A high-cost penalty on the no-load losses or noise will generally result in more steel in the core and a higher saturation curve that yields lower harmonic currents.

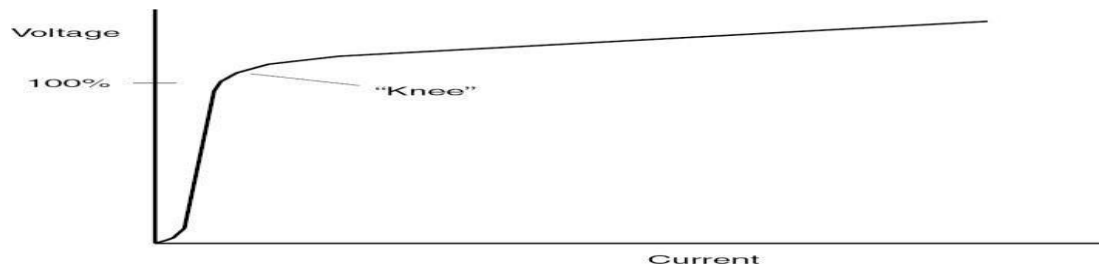

Figure 4.15 Transformer magnetizing characteristic.

Although transformer exciting current is rich in harmonics at normal operating voltage (see Fig. 4.16), it is typically less than 1 percent of rated full load current. Transformers are not as much of a concern as electronic power converters and arcing devices which can produce harmonic currents of 20 percent of their rating, or higher. However, their effect will be noticeable, particularly on utility distribution systems, which have hundreds of transformers. It is common to notice a significant increase in triplen harmonic currents during the early morning hours when the load is low and the voltage rises. Transformer exciting current is more visible then because there is insufficient load to obscure it and the increased voltage causes more current to be produced. Harmonic voltage distortion from transformer over excitation is generally only apparent under these light load conditions.

Some transformers are purposefully operated in the saturated region. One example is a triplen transformer used to generate 180 Hz for induction furnaces.

Motors also exhibit some distortion in the current when overexcited, although it is generally of little consequence. There are, however, some fractional horsepower, single-phase motors that have a nearly triangular waveform with significant third-harmonic currents.

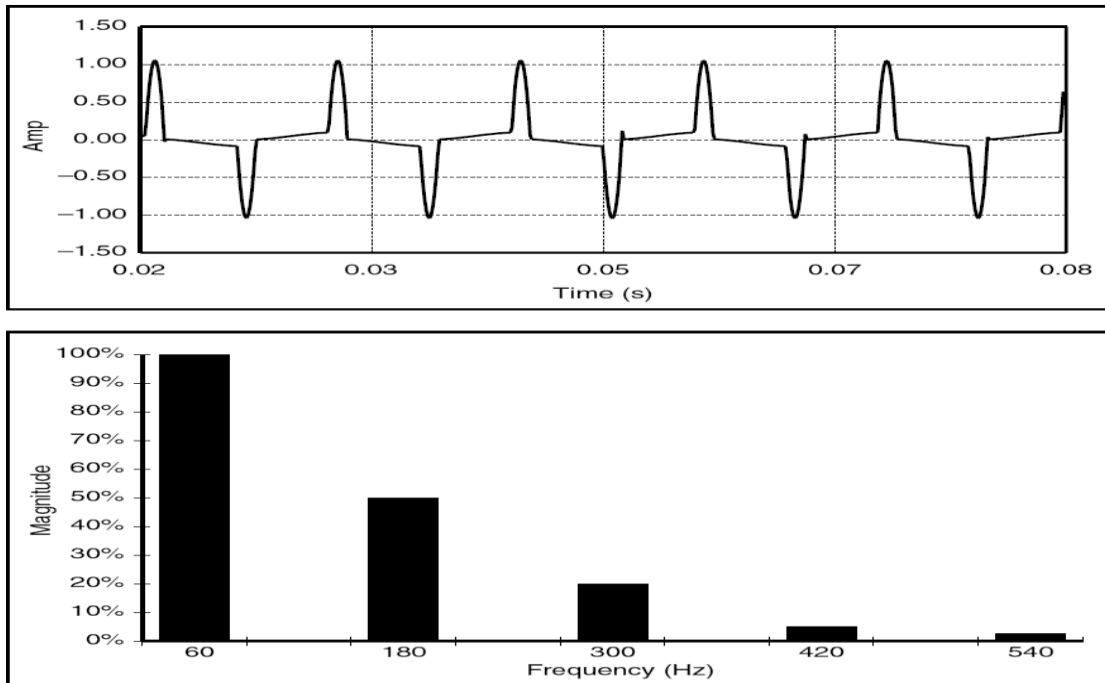

Figure 4.16 Transformer magnetizing current and harmonic spectrum.

Locating Harmonic Sources:

When harmonic problems are caused by excessive voltage distortion on the supply system, it is important to locate the sources of harmonics in order to develop a solution to the problems. Using a power quality monitor capable of reporting the harmonic content of the current, simply measure the harmonic currents in each branch starting at the beginning of the circuit and trace the harmonics to the source.

There are two basic approaches to find the sources of harmonic currents on the power systems:

1. Compare the time variations of the voltage distortion with specific customer and load characteristics.
2. Monitor flow of harmonic currents on the feeder with capacitor banks off.

Power System Response Characteristics:

The power system response characteristics are:

1. The system impedance characteristics

2. The presence of a capacitor bank causing resonance
3. The amount of resistive loads in the system

1. System impedance

At the fundamental frequency, power systems are primarily inductive, and the equivalent impedance is sometimes called simply the short-circuit reactance. Capacitive effects are frequently neglected on utility distribution systems and industrial power systems. One of the most frequently used quantities in the analysis of harmonics on power systems is the short-circuit impedance to the point on a network at which a capacitor is located. If not directly available, it can be computed from short-circuit study results that give either the short-circuit mega volt ampere (MVA) or the short-circuit current as follows:

$$Z_{SC} = R_{SC} + jX_{SC} = \frac{\text{kV}^2}{\text{MVA}_{SC}} = \frac{\text{kV} \times 1000}{\sqrt{3}I_{SC}}$$

where Z_{SC} = short-circuit impedance
 R_{SC} = short-circuit resistance
 X_{SC} = short-circuit reactance
kV = phase-to-phase voltage, kV
 MVA_{SC} = three-phase short-circuit MVA
 I_{SC} = short-circuit current, A

Z_{SC} is a phasor quantity, consisting of both resistance and reactance. However, if the short-circuit data contain no phase information, one is usually constrained to assuming that the impedance is purely reactive. This is a reasonably good assumption for industrial power systems for buses close to the mains and for most utility systems. When this is not the case, an effort should be made to determine a more realistic resistance value because that will affect the results once capacitors are considered. The inductive reactance portion of the impedance changes linearly with frequency. One common error made by novices in harmonic analysis is to forget to adjust the reactance for frequency. The reactance at the h th harmonic is determined from the fundamental impedance reactance X_1 by:

$$X_h = hX_1$$

In most power systems, one can generally assume that the resistance does not change significantly when studying the effects of harmonics less than the ninth. For lines and cables, the resistance varies approximately by the square root of the frequency once skin effect becomes significant in the conductor at a higher frequency. The exception to this rule is with some transformers.

Because of stray eddy current losses, the apparent resistance of larger transformers may vary almost proportionately with the frequency. This can have a very beneficial effect on damping of resonance as will be shown later. In smaller transformers, less than 100 kVA, the resistance of the winding is often so large relative to the other impedances that it swamps out the stray eddy current effects and there is little change in the total apparent resistance until the frequency reaches about 500 Hz. Of course, these smaller transformers may have an X/R ratio of 1.0 to 2.0 at fundamental frequency, while large substation transformers might typically have a ratio of 20 to 30. Therefore, if the bus that is being studied is dominated by transformer impedance rather than line impedance, the system impedance model should be considered more carefully. Neglecting the resistance will generally give a conservatively high prediction of the harmonic distortion.

At utilization voltages, such as industrial power systems, the equivalent system reactance is often dominated by the service transformer impedance. A good approximation for X_{SC} may be based on the impedance of the service entrance transformer only:

$$X_{SC} \approx X_{tx}$$

While not precise, this is generally at least 90 percent of the total impedance and is commonly more. This is usually sufficient to evaluate whether or not there will be a significant harmonic resonance problem. Transformer impedance in ohms can be determined from the percent impedance Z_{tx} found on the nameplate by

$$X_{tx} = \left(\frac{\text{kV}^2}{\text{MVA}_{3\phi}} \right) \times Z_{tx} (\%)$$

where $MVA_{3\phi}$ is the kVA rating of the transformer. This assumes that the impedance is predominantly reactive. For example for a 1500-kVA, 6 percent transformer, the equivalent impedance on the 480-V side is

$$X_{tx} = \left(\frac{kV^2}{MVA_{3\phi}} \right) \times Z_{tx} (\%) = \left(\frac{0.480^2}{1.5} \right) \times 0.06 = 0.0092 \Omega$$

A plot of impedance versus frequency for an inductive system (no capacitors installed) would look like Fig. 4.19. Real power systems are not quite as well behaved. This simple model neglects capacitance, which cannot be done for harmonic analysis.

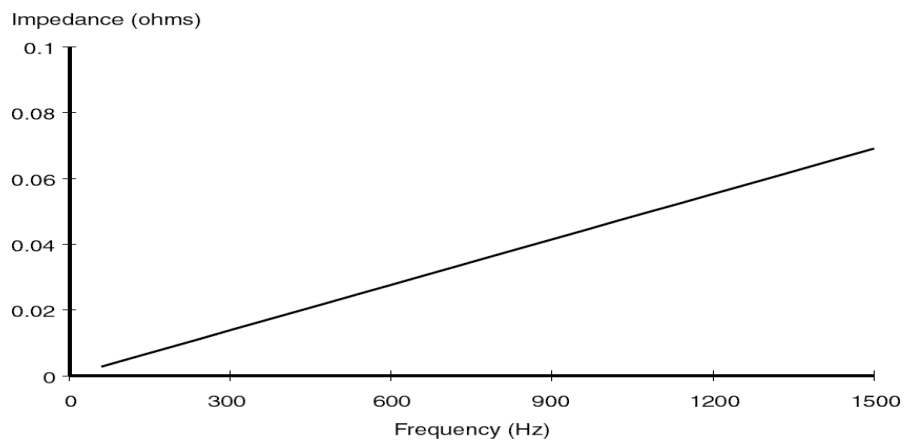

Figure 4.19 Impedance versus frequency for inductive system.

2. Capacitor impedance

Shunt capacitors, either at the customer location for power factor correction or on the distribution system for voltage control, dramatically alter the system impedance variation with frequency. Capacitors do not create harmonics, but severe harmonic distortion can sometimes be attributed to their presence. While the reactance of inductive components increases proportionately to frequency, capacitive reactance X_C decreases proportionately:

$$X_C = \frac{1}{2\pi fC}$$

C is the capacitance in farads. This quantity is seldom readily available for power capacitors, which are rated in terms of kvar or Mvar at a given voltage. The equivalent line-to-neutral capacitive reactance at fundamental frequency for a capacitor bank can be determined by

$$X_C = \frac{\text{kV}^2}{\text{Mvar}}$$

For three-phase banks, use phase-to-phase voltage and the three phase reactive power rating. For single-phase units, use the capacitor voltage rating and the reactive power rating. For example, for a three phase, 1200-kvar, 13.8-kV capacitor bank, the positive-sequence reactance in ohms would be

$$X_C = \frac{\text{kV}^2}{\text{Mvar}} = \frac{13.8^2}{1.2} = 158.7 \Omega$$

Parallel resonance

All circuits containing both capacitances and inductances have one or more natural frequencies. When one of those frequencies lines up with a frequency that is being produced on the power system, a resonance may develop in which the voltage and current at that frequency continue to persist at very high values. This is the root of most problems with harmonic distortion on power systems. Figure 4.20 shows a distribution system with potential parallel resonance problems. From the perspective of harmonic sources the shunt capacitor appears in parallel with the equivalent system inductance (source and transformer inductances) at harmonic frequencies as depicted in Fig. 4.21b. Furthermore, since the power system is assumed to have an equivalent voltage source of fundamental frequency only, the power system voltage source appears short circuited in the figure. Parallel resonance occurs when the reactance of XC and the distribution system cancel each other out. The frequency at which this phenomenon occurs is called the parallel resonant frequency. It can be expressed as follows:

$$f_p = \frac{1}{2\pi} \sqrt{\frac{1}{L_{eq}C} - \frac{R^2}{4L_{eq}^2}} \approx \frac{1}{2\pi} \sqrt{\frac{1}{L_{eq}C}}$$

At the resonant frequency, the apparent impedance of the parallel combination of the equivalent inductance and capacitance as seen from the harmonic current source becomes very large.

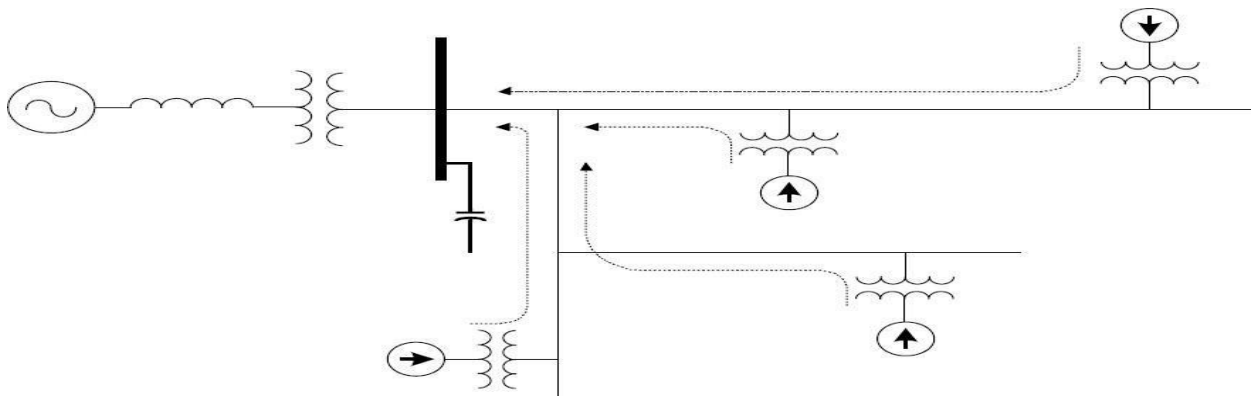

Figure 4.20 System with potential parallel resonance problems.

11.

Where $Q = \frac{X_L}{R} = \frac{X_C}{R}$ and $R = X_{Leq}$. Keep in mind that the reactance in this equation are computed at the resonant frequency.

Q often is known as the quality factor of a resonant circuit that determines the sharpness of the frequency response. Q varies considerably by location on the power system. It might be less than 5 on a distribution feeder and more than 30 on the secondary bus of a large step-down transformer. From Eq. (5.22), it is clear that during parallel resonance, a small harmonic current can cause a large voltage drop across the apparent impedance, i.e., $V_p = Q X_{Leq} I_h$. The voltage near the capacitor bank will be magnified and heavily distorted. Let us now examine current behavior during the parallel resonance. Let the current flowing in the capacitor bank or into the power system be $I_{resonance}$; thus,

$$I_{resonance} = \frac{V_p}{X_C} = \frac{Q X_C I_h}{X_C} = Q I_h$$

(or)

$$I_{resonance} = \frac{V_p}{X_{Leq}} = \frac{Q X_{Leq} I_h}{X_{Leq}} = Q I_h$$

From Eq. It is clear that currents flowing in the capacitor bank and in the power system (i.e., through the transformer) will also be magnified Q times. This phenomenon will likely cause capacitor failure, fuse blowing, or transformer overheating.

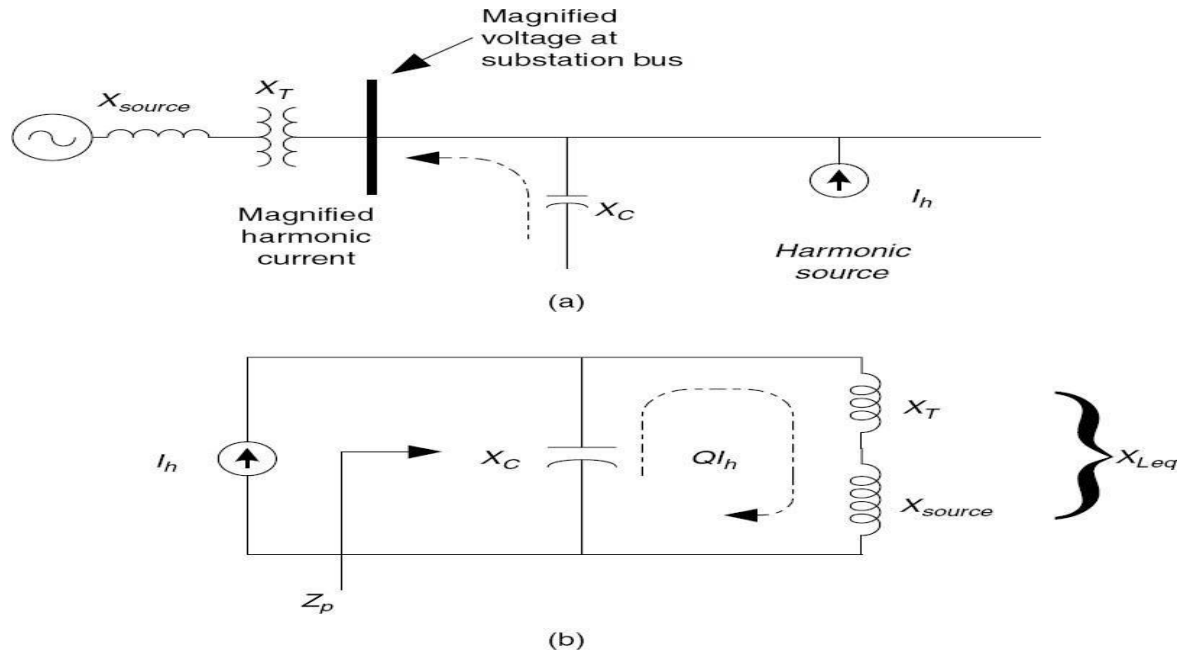

Fig 4.21 at harmonic frequencies, the shunt capacitor bank appears in parallel with the system inductance. (a) Simplified distribution circuit; (b) parallel resonant circuit as seen from the harmonic source.

The extent of voltage and current magnification is determined by the size of the shunt capacitor bank. Fig 4.22 shows the effect of varying capacitor size in relation to the transformer on the impedance seen from the harmonic source and compared with the case in which there is no capacitor. The following illustrates how the parallel resonant frequency is computed. Power systems analysts typically do not have L and C readily available and prefer to use other forms of this relationship. They commonly compute the resonant harmonic h_r based on fundamental frequency impedances and ratings using one of the following:

$$h_r = \sqrt{\frac{X_C}{X_{SC}}} = \sqrt{\frac{\text{MVA}_{SC}}{\text{Mvar}_{cap}}} \approx \sqrt{\frac{\text{kVA}_{tx} \times 100}{\text{kvar}_{cap} \times Z_{tx} (\%)}}$$

where h_r = resonant harmonic
 X_C = capacitor reactance

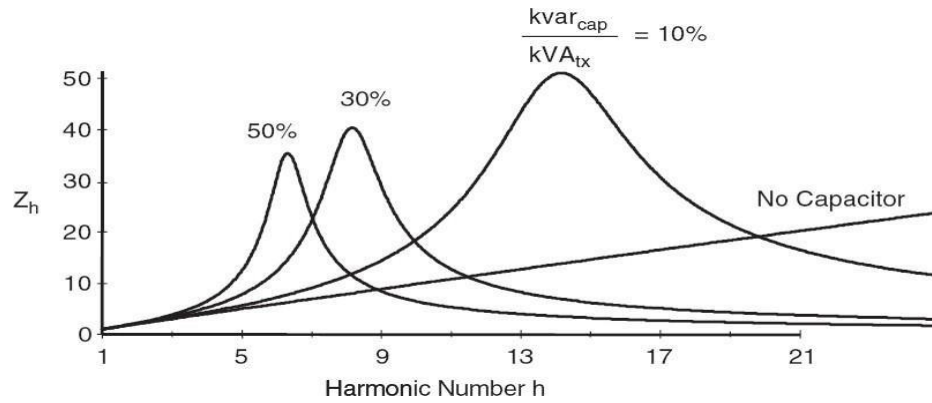

Fig 4.22 System frequency response as capacitor size is varied in relation to transformer.

$$\begin{aligned}
 X_{SC} &= \text{system short-circuit reactance} \\
 \text{MVA}_{SC} &= \text{system short-circuit MVA} \\
 \text{MVA}_{\text{cap}} &= \text{Mvar rating of capacitor bank} \\
 \text{kVA}_{\text{tx}} &= \text{kVA rating of step-down transformer} \\
 Z_{\text{tx}} &= \text{step-down transformer impedance} \\
 \text{kvar}_{\text{cap}} &= \text{kvar rating of capacitor bank}
 \end{aligned}$$

For example, for an industrial load bus where the transformer impedance is dominant, the resonant harmonic for a 1500-kVA, 6 percent transformer and a 500-kvar capacitor bank is approximately

$$h_r \approx \sqrt{\frac{\text{kVA}_{\text{tx}} \times 100}{\text{kvar}_{\text{cap}} \times Z_{\text{tx}} (\%)}} = \sqrt{\frac{1500 \times 100}{500 \times 6}} = 7.07$$

4. Series resonance

There are certain instances when a shunt capacitor and the inductance of a transformer or distribution line may appear as a series *LC* circuit to a source of harmonic currents. If the resonant frequency corresponds to a characteristic harmonic frequency of the nonlinear load, the *LC* circuit will attract a large portion of the harmonic current that is generated in the distribution system. A customer having no nonlinear load, but utilizing power factor correction capacitors, may in this way experience high harmonic voltage distortion due to neighboring harmonic sources. This situation is depicted in Fig. 4.23.

During resonance, the power factor correction capacitor forms a series circuit with the transformer and harmonic sources. The simplified circuit is shown in Fig. 4.24. The harmonic source shown in this figure represents the total harmonics produced by other loads. The inductance in series with the capacitor is that of the service entrance transformer. The series combination of the transformer inductance and the capacitor bank is very small (theoretically zero) and only limited by its resistance. Thus the harmonic current corresponding to the resonant frequency will flow freely in this circuit. The voltage at the power factor correction capacitor is magnified and highly distorted. This is apparent from the following equation:

$$V_s \text{ (at power factor capacitor bank)} = \frac{X_c}{X_T + X_C + R} V_h \approx \frac{X_C}{R} V_h$$

where V_h and V_s are the harmonic voltage corresponding to the harmonic current I_h and the voltage at the power factor capacitor bank, respectively. The resistance R of the series resonant circuit is not shown in Fig. 4.24, and it is small compared to the reactance.

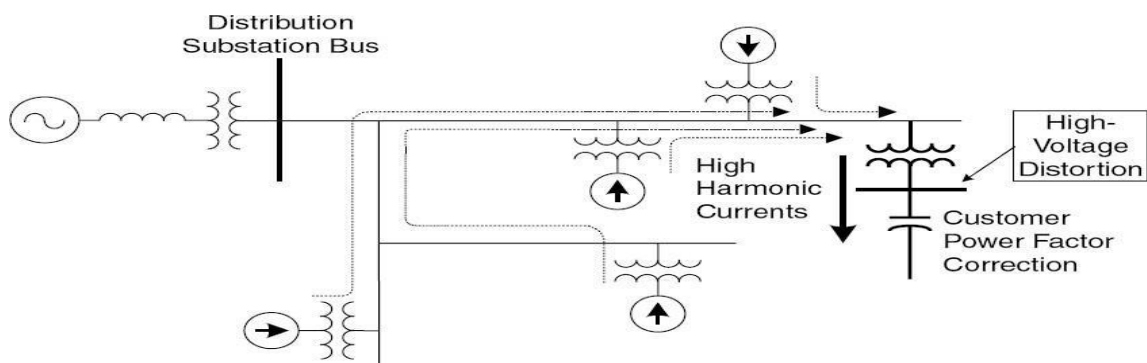

Figure 4.23 System with potential series resonance problems.

The negligible impedance of the series resonant circuit can be exploited to absorb desired harmonic currents. This is indeed the principle in designing a notch filter. In many systems with potential series resonance problems, parallel resonance also arises due to the circuit topology. One of these is shown in Fig. 4.24 where the parallel resonance is formed by the parallel combination between X source and a series between X_T and X_C . The resulting parallel resonant frequency is always smaller than its series resonant frequency due to the source inductance contribution. The parallel resonant frequency can be represented by the following equation:

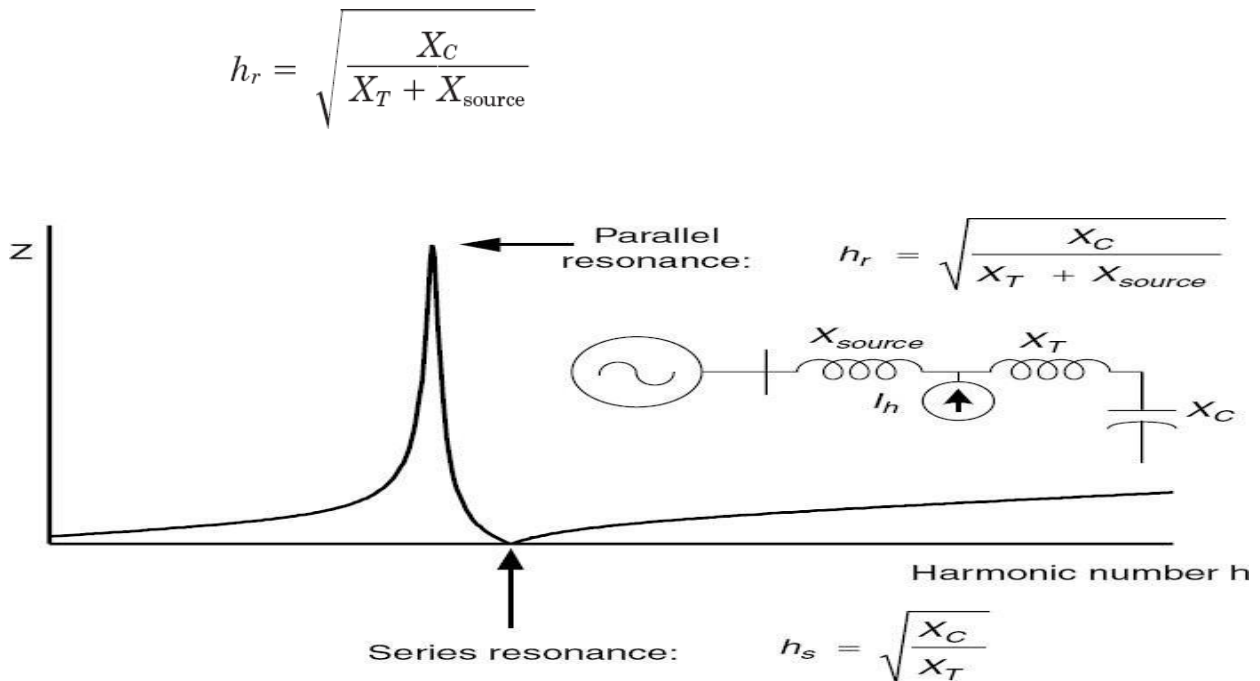

Figure 4.24 Frequency response of a circuit with series resonance.

Effects of Harmonics:

Introduction

Harmonics in electrical system result in waveform distortion. They are periodic disturbance in voltage and current. Any non sinusoidal periodic waveforms can be considered as combination of sine waveform of certain frequency, amplitude and phase angle. Generally these are individual multiple of fundamental frequency. Hence 3rd order frequency has got frequency of 150 Hz, and the 5th order harmonic has 250 frequency and so on. The amplitude and phase angle of individual components will vary depending on the nature of distorted waveform.

THD is defined as the ratio of the root mean square value of the harmonic content to root mean square value of the fundamental quantity, expressed as percent of the fundamental. It is measured of effective value of harmonic distortion.

The total harmonic value of distortion (THD) is the value used to describe the characteristics of distorted waveform. The THD is a measured of how badly the waveform is distorted from pure sinusoidal the THD is 0%. IEEE standard 519 recommends that for most

system, the THD of the bus voltage should be less than 5% with maximum of 3% with any individual components.

Harmonic Distortion

Harmonic distortion is caused by nonlinear devices in the power system. A nonlinear device is one in which the current is not proportional to the applied voltage. Figure 4.1 illustrates this concept by the case of a sinusoidal voltage applied to a simple nonlinear resistor in which the voltage and current vary according to the curve shown. While the applied voltage is perfectly sinusoidal, the resulting current is distorted. Increasing the voltage by a few percent may cause the current to double and take on a different wave shape. This is the source of most harmonic distortion in a power system.

Figure 4.2 illustrates that any periodic, distorted waveform can be expressed as a sum of sinusoids. When a waveform is identical from one cycle to the next, it can be represented as a sum of pure sine waves in which the frequency of each sinusoid is an integer multiple of the fundamental frequency of the distorted wave. This multiple is called a *harmonic* of the fundamental, hence the name of this subject matter. The sum of sinusoids is referred to as a *Fourier series*, named after the great mathematician who discovered the concept.

Because of the above property, the Fourier series concept is universally applied in analyzing harmonic problems. The system can now be analyzed separately at each harmonic. In addition, finding the system response of a sinusoid of each harmonic individually is much more straightforward compared to that with the entire distorted waveforms. The outputs at each frequency are then combined to form a new Fourier series, from which the output waveform may be computed, if desired. Often, only the magnitudes of the harmonics are of interest.

When both the positive and negative half cycles of a waveform have identical shapes, the Fourier series contains only *odd* harmonics. This offers a further simplification for most power system studies because most common harmonic-producing devices look the same to both polarities. In fact, the presence of even harmonics is often a clue that there is something wrong—either with the load equipment or with the transducer used to make the measurement. There are notable exceptions to this such as half-wave rectifiers and arc furnaces when the arc is random.

Usually, the higher-order harmonics (above the range of the 25th to 50th, depending on the system) are negligible for power system analysis. While they may cause interference with low-power electronic devices, they are usually not damaging to the power system. It is also difficult to collect sufficiently accurate data to model power systems at these frequencies.

A common exception to this occurs when there are system resonances in the range of frequencies. These resonances can be excited by notching or switching transients in electronic power converters. This causes voltage waveforms with multiple zero crossings which disrupt timing circuits. These resonances generally occur on systems with underground cable but no power factor correction capacitors.

If the power system is depicted as series and shunt elements, as is the conventional practice, the vast majority of the nonlinearities in the system are found in *shunt* elements (i.e., loads). The series impedance of the power delivery system (i.e., the short-circuit impedance between the source and the load) is remarkably linear. In transformers, also, the source of harmonics is the shunt branch (magnetizing impedance) of the common “T” model; the leakage impedance is linear. Thus, the main sources of harmonic distortion will ultimately be end-user loads. This is not to say that all end users who experience harmonic distortion will themselves have significant sources of harmonics, but that the harmonic distortion generally originates with some end-user’s load or combination of loads.

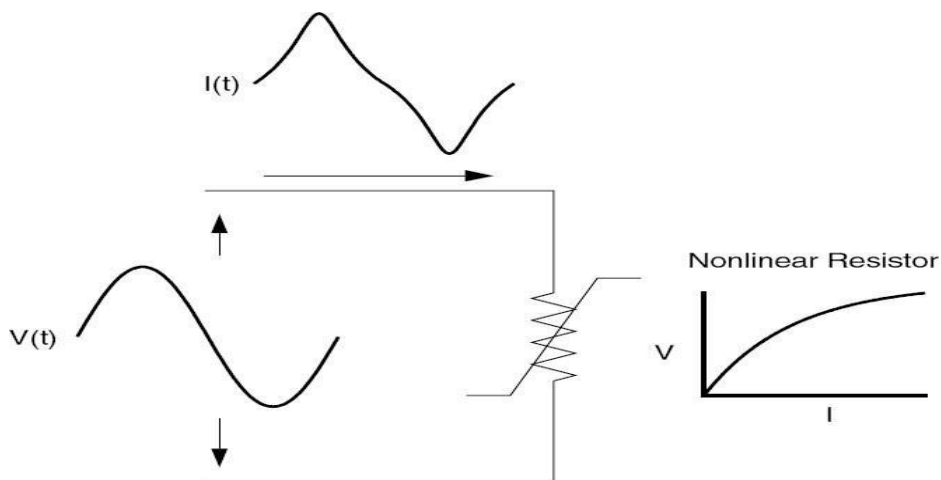

Fig 4.1 Current distortion caused by nonlinear resistance.

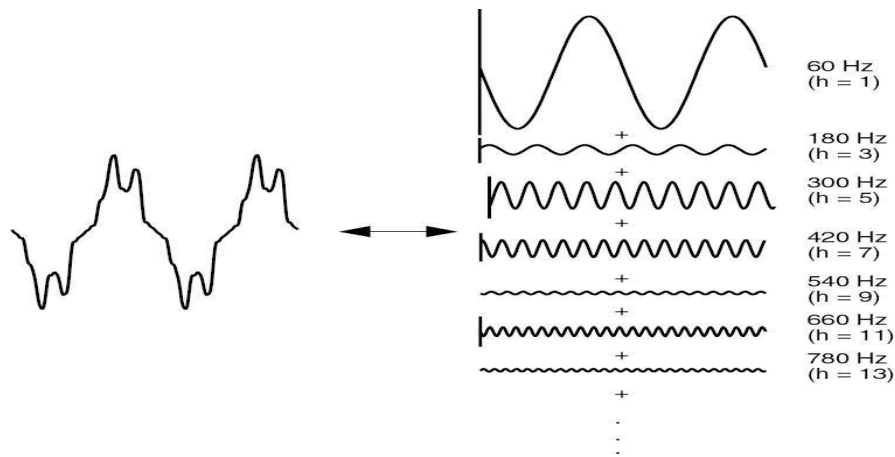

Fig 4.2 Fourier series representation of a distorted waveform.

Voltage versus Current Distortion

The word harmonics is often used by itself without further qualification. For example, it is common to hear that an adjustable-speed drive or an induction furnace can't operate properly because of harmonics. What does that mean? Generally, it could mean one of the following

Three things:

1. The harmonic voltages are too great (the voltage too distorted) for the control to properly determine firing angles.
2. The harmonic currents are too great for the capacity of some device in the power supply system such as a transformer, and the machine must be operated at a lower than rated power.
3. The harmonic voltages are too great because the harmonic currents produced by the device are too great for the given system condition.

As suggested by this list, there are separate causes and effects for voltages and currents as well as some relationship between them. Thus, the term harmonics by itself is inadequate to definitively describe a problem.

Nonlinear loads appear to be sources of harmonic current in shunt with and injecting harmonic currents into the power system. For nearly all analyses, it is sufficient to treat these

harmonic-producing loads simply as current sources. There are exceptions to this as will be described later.

As Fig. 4.3 shows, voltage distortion is the result of distorted currents passing through the linear, series impedance of the power delivery system, although, assuming that the source bus is ultimately a pure sinusoid, there is a nonlinear load that draws a distorted current. The harmonic currents passing through the impedance of the system cause a voltage drop for each harmonic. This results in voltage harmonics appearing at the load bus. The amount of voltage distortion depends on the impedance and the current. Assuming the load bus distortion stays within reasonable limits (e.g., less than 5 percent), the amount of harmonic current produced by the load is generally constant.

While the load current harmonics ultimately cause the voltage distortion, it should be noted that load has no control over the voltage distortion. The same load put in two different locations on the power system will result in two different voltage distortion values. Recognition of this fact is the basis for the division of responsibilities for harmonic control that are found in standards such as IEEE Standard 519-1992, *Recommended Practices and Requirements for Harmonic Control in Electrical Power Systems*:

1. The control over the amount of harmonic current injected into the system takes place at the end-use application.
2. Assuming the harmonic current injection is within reasonable limits, the control over the voltage distortion is exercised by the entity having control over the system impedance, which is often the utility.

One must be careful when describing harmonic phenomena to understand that there are distinct differences between the causes and effects of harmonic voltages and currents. The use of the term harmonics should be qualified accordingly. By popular convention in the power industry, the majority of times when the term is used by itself to refer to the load apparatus, the speaker is referring to the harmonic currents. When referring to the utility system, the voltages are generally the subject. To be safe, make a habit of asking for clarification.

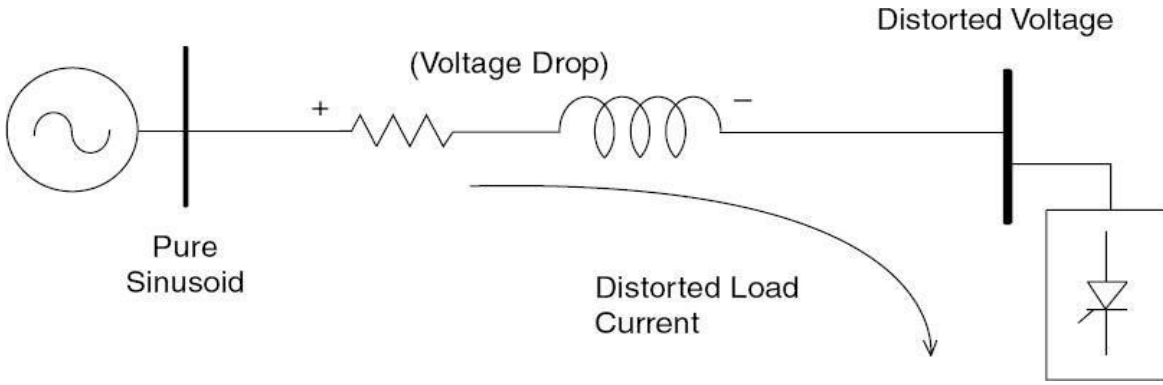

Fig 4.3 Harmonic currents flowing through the system impedance result in harmonic voltages at the load.

Harmonic Indices:

The two most commonly used indices for measuring the harmonic content of a waveform are the total harmonic distortion and the total demand distortion. Both are measures of the effective value of a waveform and may be applied to either voltage or current.

Total harmonic distortion

The THD is a measure of the *effective value* of the harmonic components of a distorted waveform. That is, it is the potential heating value of the harmonics relative to the fundamental. This index can be calculated for either voltage or current:

$$\text{THD} = \frac{\sqrt{\sum_{h>1}^{h_{\max}} M_h^2}}{M_1} \quad (4.1)$$

where M_h is the rms value of harmonic component h of the quantity M .

The rms value of a distorted waveform is the square root of the sum of the squares as shown in Eqs. (4.1) and (4.2). The THD is related to the rms value of the waveform as follows:

$$\text{RMS} = \sqrt{\sum_{h=1}^{h_{\max}} M_h^2} = M_1 \sqrt{1 + \text{THD}^2} \quad (4.2)$$

The THD is a very useful quantity for many applications, but its limitations must be realized. It can provide a good idea of how much extra heat will be realized when a distorted voltage is applied across a resistive load. Likewise, it can give an indication of the additional losses caused by the current flowing through a conductor. However, it is not a good indicator of the voltage stress within a capacitor because that is related to the peak value of the voltage waveform, not its heating value.

The THD index is most often used to describe voltage harmonic distortion. Harmonic voltages are almost always referenced to the fundamental value of the waveform at the time of the sample. Because fundamental voltage varies by only a few percent, the voltage THD is nearly always a meaningful number. Variations in the THD over a period of time often follow a distinct pattern representing nonlinear load activities in the system. Figure 4.4 shows the voltage THD variation over a 1-week period where a daily cyclical pattern is obvious. The voltage THD shown in Fig. 4.4 was taken at a 13.2-kV distribution substation supplying a residential load. High-voltage THD occurs at night and during the early morning hours since the nonlinear loads are relatively high compared to the amount of linear load during these hours. A 1-week observation period is often required to come up with a meaningful THD pattern since it is usually the shortest period to obtain representative and reproducible measurement results.

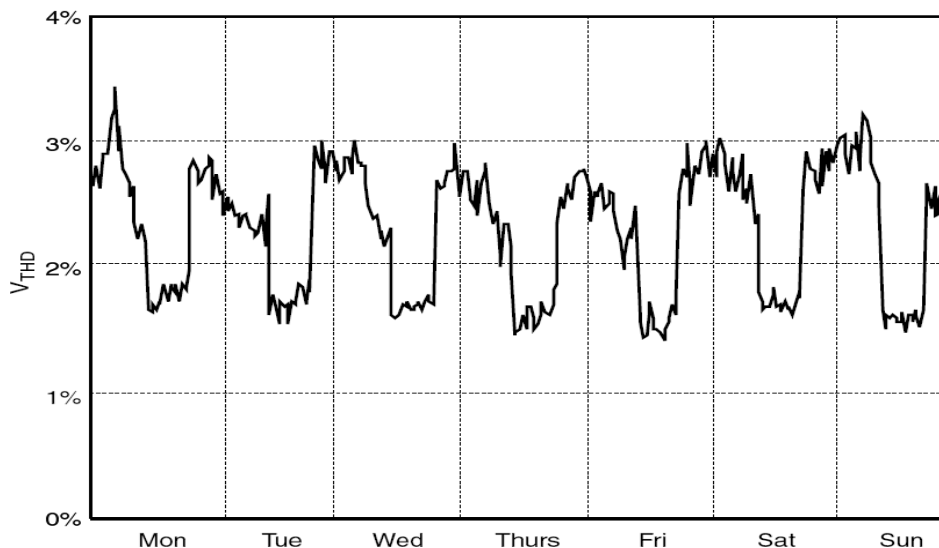

Fig 4.4 Variation of the voltage THD over a 1-week period.

Total demand distortion

Current distortion levels can be characterized by a THD value, as has been described, but this can often be misleading. A small current may have a high THD but not be a significant threat to the system. For example, many adjustable-speed drives will exhibit high THD values for the input current when they are operating at very light loads. This is not necessarily a significant concern because the magnitude of harmonic current is low, even though its relative current distortion is high.

Some analysts have attempted to avoid this difficulty by referring THD to the fundamental of the peak demand load current rather than the fundamental of the present sample. This is called total demand distortion and serves as the basis for the guidelines in IEEE Standard 519-1992, *Recommended Practices and Requirements for Harmonic Control in Electrical Power Systems*. It is defined as follows:

$$\text{TDD} = \frac{\sqrt{\sum_{h=2}^{h_{\max}} I_h^2}}{I_L} \quad (4.1)$$

I_L is the peak, or maximum, demand load current at the fundamental frequency component measured at the point of common coupling (PCC). There are two ways to measure I_L . With a load already in the system, it can be calculated as the average of the maximum demand current for the preceding 12 months. The calculation can simply be done by averaging the 12-month peak demand readings. For a new facility, I_L has to be estimated based on the predicted load profiles.

Harmonic Distortion Evaluation:

The interaction often gives rise to voltage and current harmonic distortion observed in many places in the system. Therefore, to limit both voltage and current harmonic distortion, IEEE Standard 519-1992 proposes to limit harmonic current injection from end users so that harmonic voltage levels on the overall power system will be acceptable if the power system does

not inordinately accentuate the harmonic currents. This approach requires participation from both end users and utilities.1–3

1. End users. For individual end users, IEEE Standard 519-1992 limits the level of harmonic current injection at the point of common coupling (PCC). This is the quantity end users have control over. Recommended limits are provided for both individual harmonic components and the total demand distortion. The concept of PCC is illustrated in Fig. 4.25. These limits are expressed in terms of a percentage of the end user's maximum demand current level, rather than as a percentage of the fundamental. This is intended to provide a common basis for evaluation over time.

2. The utility. Since the harmonic voltage distortion on the utility system arises from the interaction between distorted load currents and the utility system impedance, the utility is mainly responsible for limiting the voltage distortion at the PCC. The limits are given for the maximum individual harmonic components and for the total harmonic distortion (THD). These values are expressed as the percentage of the fundamental voltage. For systems below 69 kV, the THD should be less than 5 percent. Sometimes the utility system impedance at harmonic frequencies is determined by the resonance of power factor correction capacitor banks. This results in a very high impedance and high harmonic voltages. Therefore, compliance with IEEE Standard 519-1992 often means that the utility must ensure that system resonances do not coincide with harmonic frequencies present in the load currents. Thus, in principle, end users and utilities share responsibility for limiting harmonic current injections and voltage distortion at the PCC. Since there are two parties involved in limiting harmonic distortions, the evaluation of harmonic distortion is divided into two parts: measurements of the currents being injected by the load and calculations of the frequency response of the system impedance. Measurements should be taken continuously over a sufficient period of time so that time variations and statistical characteristics of the harmonic distortion can be accurately represented. Sporadic measurements should be avoided since they do not represent harmonic characteristics accurately given that harmonics are a continuous phenomenon. The minimum measurement period is usually 1 week since this provides a representative loading cycle for most industrial and commercial loads.

Concept of point of common coupling

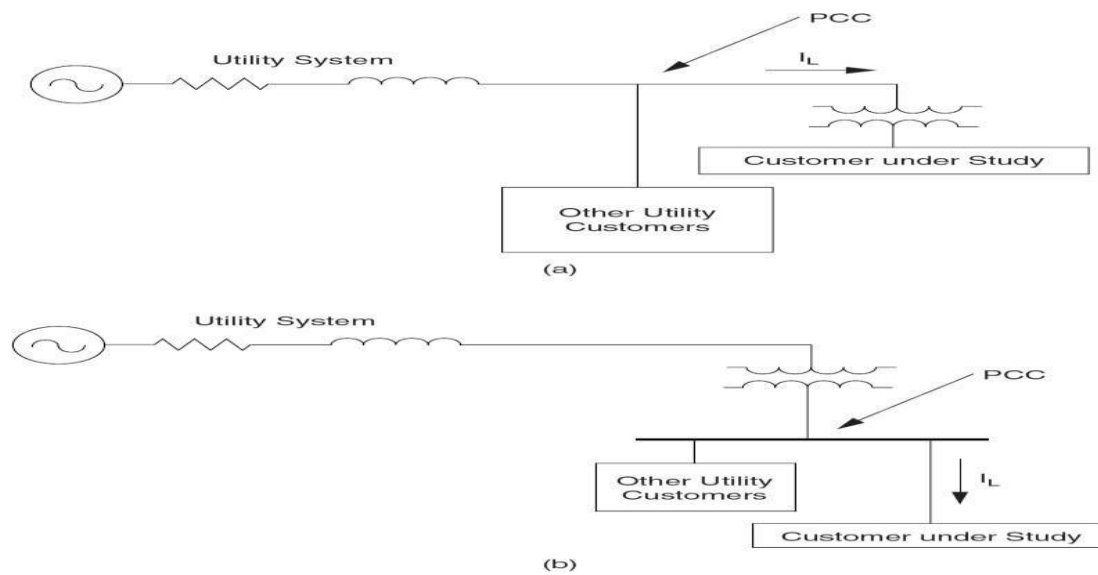

Figure 4.25 PCC selection depends on where multiple customers are served. (a) PCC at the transformer primary where multiple customers are served. (b) PCC at the transformer secondary where multiple customers are served.

Evaluations of harmonic distortion are usually performed at a point between the end user or customer and the utility system where another customer can be served. This point is known as the point of common coupling.¹

The PCC can be located at either the primary side or the secondary side of the service transformer depending on whether or not multiple customers are supplied from the transformer. In other words, if multiple customers are served from the primary of the transformer, the PCC is then located at the primary. On the other hand, if multiple customers are served from the secondary of the transformer, the PCC is located at the secondary. Figure 4.25 illustrates these two possibilities.

Note that when the primary of the transformer is the PCC, current measurements for verification can still be performed at the transformer secondary. The measurement results should be referred to the transformer high side by the turns ratio of the transformer, and the effect of transformer connection on the zero-sequence components must be taken into account. For instance, a delta-wye connected transformer will not allow zero-sequence current components to flow from the secondary to the primary system. These secondary components will be trapped in

the primary delta winding. Therefore, zero-sequence components (which are balanced triplen harmonic components) measured on the secondary side would not be included in the evaluation for a PCC on the primary side.

Harmonic evaluations on the utility system

Harmonic evaluations on the utility system involve procedures to determine the acceptability of the voltage distortion for all customers. Should the voltage distortion exceed the recommended limits, corrective actions will be taken to reduce the distortion to a level within limits. IEEE Standard 519-1992 provides guidelines for acceptable levels of voltage distortion on the utility system. These are summarized in Table 4.1. Note that the recommended limits are specified for the maximum individual harmonic component and for the THD.

Note that the definition of the total harmonic distortion in Table 4.1 is slightly different than the conventional definition. The THD value in this table is expressed as a function of the nominal system rms voltage rather than of the fundamental frequency voltage magnitude at the time of the measurement. The definition used here allows the evaluation of the voltage distortion with respect to fixed limits rather than limits that fluctuate with the system voltage. A similar concept is applied for the current limits.

There are two important components for limiting voltage distortion levels on the overall utility system:

- 1.** Harmonic currents injected from individual end users on the system must be limited. These currents propagate toward the supply source through the system impedance, creating voltage distortion. Thus by limiting the amount of injected harmonic currents, the voltage distortion can be limited as well. This is indeed the basic method of controlling the overall distortion levels proposed by IEEE Standard 519- 1992.

- 2.** The overall voltage distortion levels can be excessively high even if the harmonic current injections are within limits. This condition occurs primarily when one of the harmonic current frequencies is close to a system resonance frequency. This can result in unacceptable voltage distortion levels at some system locations. The highest voltage distortion will generally occur at a capacitor bank that participates in the resonance. This location can be remote from the point of injection.

Table 4.1 Harmonic Voltage Distortion Limits in Percent of

Nominal Fundamental Frequency Voltage

Bus voltage at PCC, V_n (kV)	Individual harmonic voltage distortion (%)	Total voltage distortion, THD_{V_n} (%)
$V_n \leq 69$	3.0	5.0
$69 < V_n \leq 161$	1.5	2.5
$V_n > 161$	1.0	1.5

SOURCE: IEEE Standard 519-1992, table 11.1.

Voltage limits evaluation procedure:

The overall procedure for utility system harmonic evaluation is described here. This procedure is applicable to both existing and planned installations. Figure 4.26 shows a flowchart of the evaluation procedure.

1. **Characterization of harmonic sources.** Characteristics of harmonic sources on the system are best determined with measurements for existing installations. These measurements should be performed at facilities suspected of having offending nonlinear loads. The duration of measurements is usually at least 1 week so that all the cyclical load variations can be captured. For new or planned installations, harmonic characteristics provided by manufacturers may suffice.

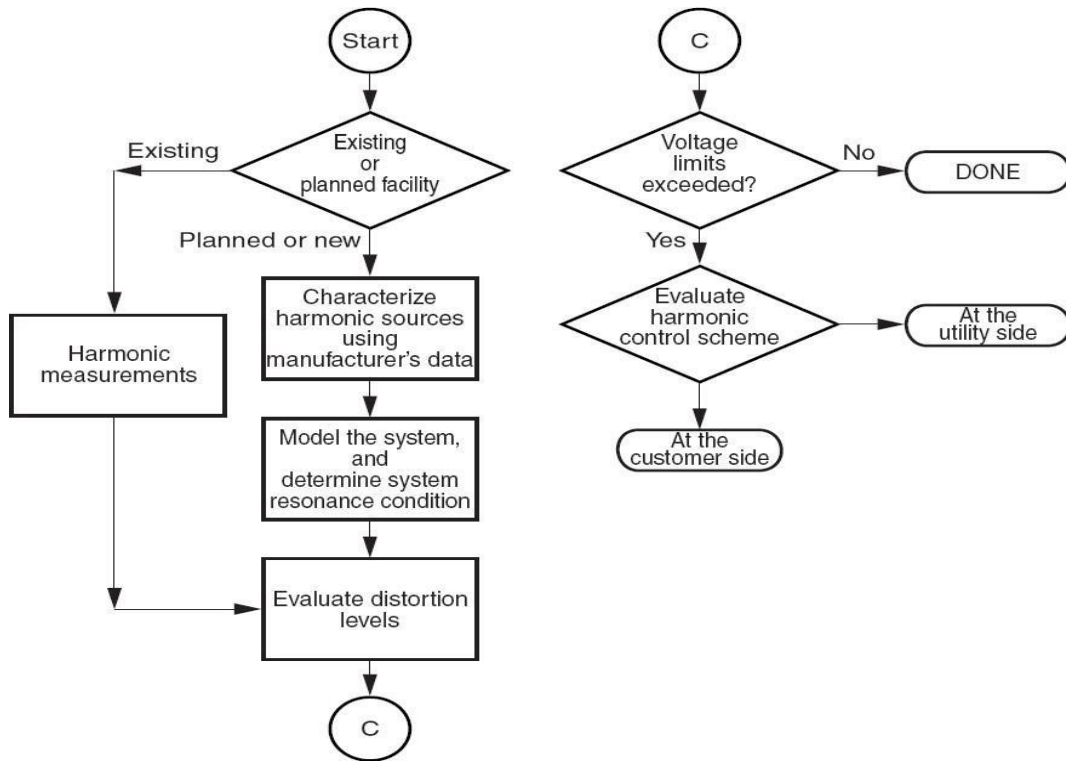

Fig 4.26 Voltage limit evaluation procedure

2. System modeling. The system response to the harmonic currents injected at end-user locations or by nonlinear devices on the power system is determined by developing a computer model of the system.

3. System frequency response. Possible system resonances should be determined by a frequency scan of the entire power delivery system. Frequency scans are performed for all capacitor bank configurations of interest since capacitor configuration is the main variable that will affect the resonant frequencies.

4. Evaluate expected distortion levels. Even with system resonance close to characteristic harmonics, the voltage distortion levels around the system may be acceptable. On distribution systems, most resonances are significantly damped by the resistances on the system, which reduces magnification of the harmonic currents. The estimated harmonic sources are used with the system configuration yielding the worst-case frequency-response characteristics to compute

the highest expected harmonic distortion. This will indicate whether or not harmonic mitigation measures are necessary.

5. Evaluate harmonic control scheme. Harmonic control options consist of controlling the harmonic injection from nonlinear loads, changing the system frequency-response characteristics, or blocking the flow of harmonic currents by applying harmonic filters. Design of Passive filters for some systems can be difficult because the system characteristics are constantly changing as loads vary and capacitor banks are switched.

Harmonic evaluation for end-user facilities:

Harmonic problems are more common at end-user facilities than on the utility supply system. Most nonlinear loads are located within end-user facilities, and the highest voltage distortion levels occur close to harmonic sources. The most significant problems occur when there are nonlinear loads and power factor correction capacitors that result in resonant conditions. IEEE Standard 519-1992 establishes harmonic current distortion limits at the PCC. The limits, summarized in Table 4.2, are dependent on the customer load in relation to the system short-circuit capacity at the PCC.

The variables and additional restrictions to the limits given in Table 4.2 are:

$V_n \leq 69 \text{ kV}$						
I_{SC}/I_L	$h < 11$	$11 \leq h < 17$	$17 \leq h < 23$	$23 \leq h < 35$	$35 \leq h$	TDD
<20	4.0	2.0	1.5	0.6	0.3	5.0
20–50	7.0	3.5	2.5	1.0	0.5	8.0
50–100	10.0	4.5	4.0	1.5	0.7	12.0
100–1000	12.0	5.5	5.0	2.0	1.0	15.0
>1000	15.0	7.0	6.0	2.5	1.4	20.0
$69 \text{ kV} < V_n \leq 161 \text{ kV}$						
<20*	2.0	1.0	0.75	0.3	0.15	2.5
20–50	3.5	1.75	1.25	0.5	0.25	4.0
50–100	5.0	2.25	2.0	0.75	0.35	6.0
100–1000	6.0	2.75	2.5	1.0	0.5	7.5
>1000	7.5	3.5	3.0	1.25	0.7	10.0
$V_n > 161 \text{ kV}$						
<50	2.0	1.0	0.75	0.3	0.15	2.5
≥ 50	3.0	1.50	1.15	0.45	0.22	3.75

*All power generation equipment applications are limited to these values of current distortion regard less of the actual short-circuit current ratio I_{SC}/I_L .
SOURCE: IEEE Standard 519-1992, tables 10.3, 10.4, 10.5.

- ✓ I_h is the magnitude of individual harmonic components (rms amps).
- ✓ I_{SC} is the short-circuit current at the PCC.

- ✓ I_L is the fundamental component of the maximum demand load current at the PCC. It can be calculated as the average of the maximum monthly demand currents for the previous 12 months or it may have to be estimated.
- ✓ The individual harmonic component limits apply to the odd-harmonic components. Even-harmonic components are limited to 25 percent of the limits.
- ✓ Current distortion which results in a dc offset at the PCC is not allowed.
- ✓ The total demand distortion (TDD) is expressed in terms of the maximum demand load current, i.e.,

$$\text{TDD} = \frac{\sqrt{\frac{\sum I_h^2}{2}}}{I_L} \times 100\% \quad (4.11)$$

- ✓ If the harmonic-producing loads consist of power converters with pulse number q higher than 6, the limits indicated in Table 6.2 are increased by a factor equal to $\sqrt{q/6}$.

In computing the short-circuit current at the PCC, the normal system conditions that result in minimum short-circuit capacity at the PCC should be used since this condition results in the most severe system impacts.

A procedure to determine the short-circuit ratio is as follows:

- ✓ Determine the three-phase short-circuits duty I_{SC} at the PCC. This value may be obtained directly from the utility and expressed in amperes. If the short-circuit duty is given in mega volt amperes, convert it to an amperage value using the following expression:

$$I_{sc} = \frac{1000 \times \text{MVA}}{\sqrt{3} \text{ kV}} \quad \text{A}$$

- ✓ Find the load average kilowatt demand P_D over the most recent 12 months. This can be found from billing information.
- ✓ Convert the average kilowatt demand to the average demand current in amperes using the following expression:

$$I_L = \frac{\text{kW}}{\text{PF} \sqrt{3} \text{ kV}} \quad \text{A}$$

where PF is the average billed power factor.

- ✓ The short-circuit ratio is now determined by:

$$\text{Short-circuit ratio} = \frac{I_{SC}}{I_L}$$

This is the short-circuit ratio used to determine the limits on harmonic currents in IEEE Standard 519-1992.

In some instances, the average of the maximum demand load current at the PCC for the previous 12 months is not available. In such circumstances, this value must be estimated based on the predicted load profiles. For seasonal loads, the average should be over the maximum loads only.

Devices for Controlling Harmonic Distortion

There are a number of devices available to control harmonic distortion. They can be as simple as a capacitor bank or a line reactor, or as complex as an active filter.

PASSIVE FILTERS:

Passive filters are inductance, capacitance, and resistance elements configured and tuned to control harmonics. They are commonly used and are relatively inexpensive compared with other means for eliminating harmonic distortion. However, they have the disadvantage of potentially interacting adversely with the power system, and it is important to check all possible system interactions when they are designed. They are employed either to shunt the harmonic currents off the line or to block their flow between parts of the system by tuning the elements to create a resonance at a selected frequency. Figure 4.27 shows several types of common filter arrangements.

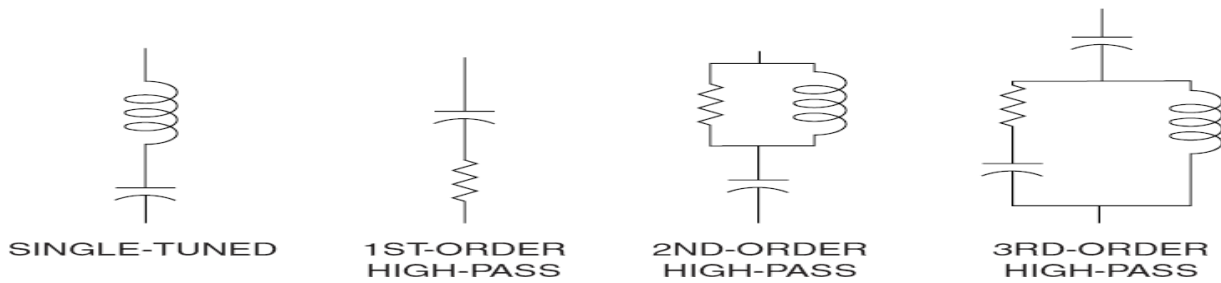

Figure 4.27 Common passive filter configurations.

SHUNT PASSIVE FILTERS:

The most common type of passive filter is the single tuned “notch” filter. This is the most economical type and is frequently sufficient for the application. The notch filter is series-tuned to present low impedance to a particular harmonic current and is connected in shunt with the power system. Thus, harmonic currents are diverted from their normal flow path on the line through the filter. Notch filters can provide power factor correction in addition to harmonic suppression. In fact, power factor correction capacitors may be used to make notch filters. The dry-type iron-core reactor is positioned atop the capacitors, which are connected in a wye, or star, configuration with the other phases (not shown). Each capacitor can be fused with a current-limiting fuse to minimize damage in case of a can failure. In outdoor installations it is often more economical to use air-core reactors.

Iron-core reactors may also be oil-insulated. Here the reactors are placed on top of the cabinet housing the capacitors and switchgear. An example of a common 480-V filter arrangement is illustrated in Fig. 4.28. The figure shows a delta-connected low-voltage capacitor bank converted into a filter by adding an inductance in series with the phases. In this case, the notch harmonic h_{notch} is related to the fundamental frequency reactances by

$$h_{\text{notch}} = \sqrt{\frac{X_C}{3X_F}} \quad (4.12)$$

Note that X_C in this case is the reactance of one leg of the delta rather than the equivalent line-to-neutral capacitive reactance.

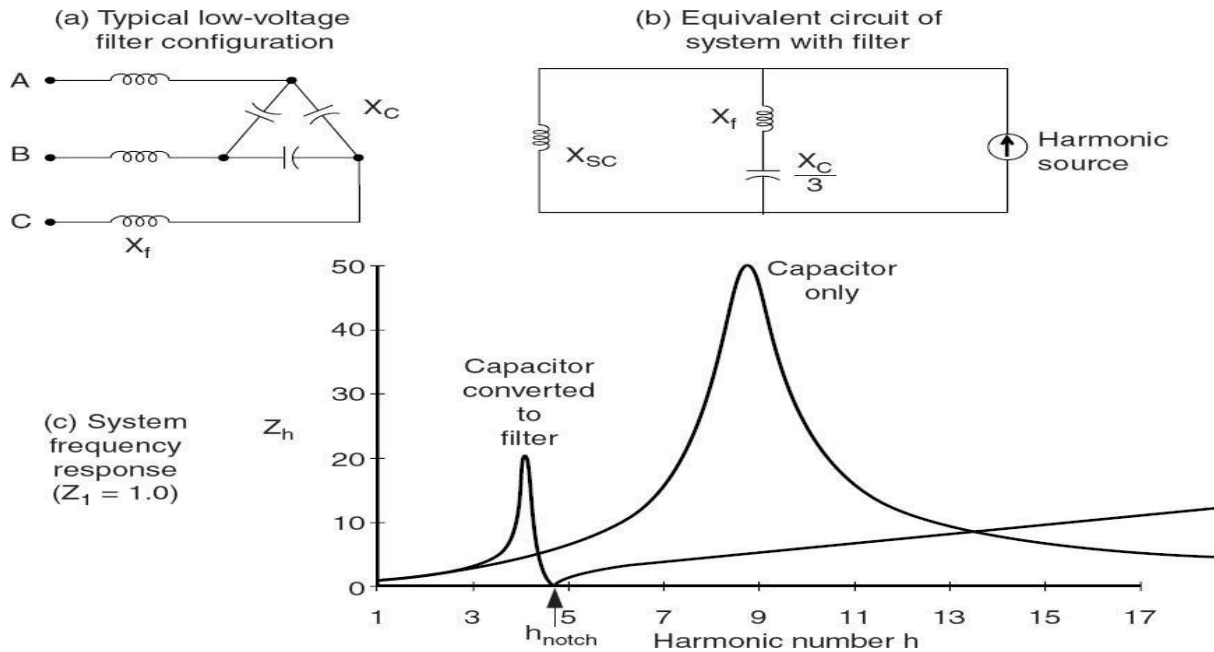

Figure 6.28 creating a fifth-harmonic notch filter and its effect on system response.

SERIES PASSIVE FILTERS:

Unlike a notch filter which is connected in shunt with the power system, a series passive filter is connected in series with the load. The inductance and capacitance are connected in parallel and are tuned to provide high impedance at a selected harmonic frequency. The high impedance then blocks the flow of harmonic currents at the tuned frequency only. At fundamental frequency, the filter would be designed to yield low impedance, thereby allowing the fundamental current to follow with only minor additional impedance and losses. Fig 4.29. Shows a typical series filter arrangement. Series filters are used to block a single harmonic current (such as the third harmonic) and are especially useful in a single-phase circuit where it is not possible to take advantage of zero-sequence characteristics. The use of the series filters is limited in blocking multiple harmonic currents. Each harmonic current requires a series filter tuned to that harmonic. This arrangement can create significant losses at the fundamental frequency.

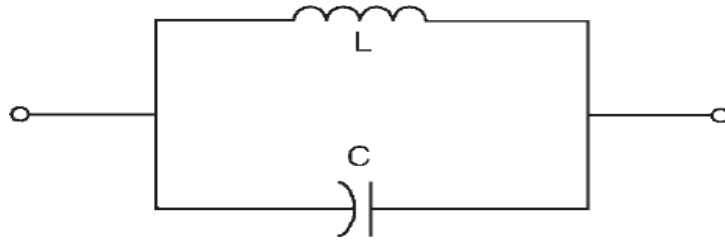

Figure 4.29 A series passive filter.

LOW-PASS BROADBAND FILTERS:

Multiple stages of both series and shunt filters are often required in practical applications. For example, in shunt filter applications, a filter for blocking a seventh-harmonic frequency would typically require two stages of shunt filters, the seventh-harmonic filter itself and the lower fifth-harmonic filter. Similarly, in series filter applications, each frequency requires a series filter of its own; thus, multiple stages of filters are needed to block multiple frequencies. In numerous power system conditions, harmonics can appear not only in a single frequency but can spread over a wide range of frequencies. A six-pulse converter generates characteristic harmonics of 5th, 7th, 11th, 13th, etc. Electronic powers converters can essentially generate time-varying inter harmonics covering a wide range of frequencies.

Designing a shunt or series filter to eliminate or reduce these widespread and time-varying harmonics would be very difficult using shunt filters. Therefore, an alternative harmonic filter must be devised. A low-pass broadband filter is an ideal application to block multiple or widespread harmonic frequencies. Current with frequency components below the filter cutoff frequency can pass; however, current with frequency components above the cutoff frequency is filtered out. Since this type of low-pass filter is typically designed to achieve a low cutoff frequency, it is then called a low-pass broadband filter. A typical configuration of a low-pass broadband filter is shown in Fig. 4.30.

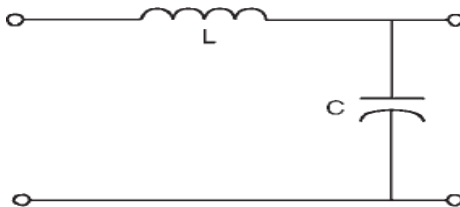

Figure 4.30 a low-pass broadband filter configuration.

C FILTERS:

C filters are an alternative to low-pass broadband filters in reducing multiple harmonic frequencies simultaneously in industrial and utility systems. They can attenuate a wide range of steady state and time-varying harmonic and inter harmonic frequencies generated by electronic converters, induction furnaces, cyclo converters, and the like.

ACTIVE FILTERS:

Active filters are relatively new types of devices for eliminating harmonics. They are based on sophisticated power electronics and are much more expensive than passive filters. However, they have the distinct advantage that they do not resonate with the system. Active filters can work independently of the system impedance characteristics. Thus, they can be used in very difficult circumstances where passive filters cannot operate successfully because of parallel resonance problems. They can also address more than one harmonic at a time and combat other power quality problems such as flicker. They are particularly useful for large, distorting loads fed from relatively weak points on the power system.

The basic idea is to replace the portion of the sine wave that is missing in the current in a nonlinear load. Figure 4.31 illustrates the concept. An electronic control monitors the line voltage and/or current, switching the power electronics very precisely to track the load current or voltage and force it to be sinusoidal. As shown, there are two fundamental approaches: one that uses an inductor to store current to be injected into the system at the appropriate instant and one that uses a capacitor. Therefore, while the load current is distorted to the extent demanded by the nonlinear load, the current seen by the system is much more sinusoidal.

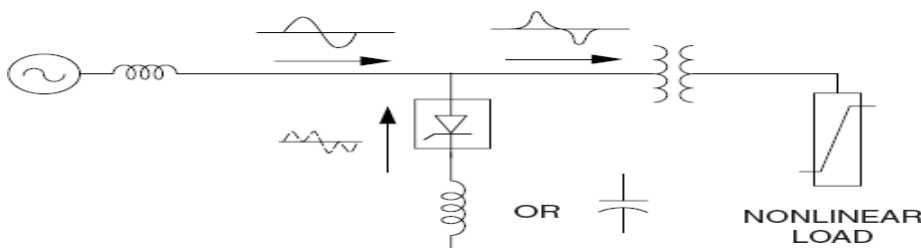

Figure 4.31 Application of an active filter at a load.

IEEE and IEC Standards:

It should be emphasized that the philosophy behind this standard seeks to limit the harmonic injection from individual customers so that they do not create unacceptable voltage distortion under normal system characteristics and to limit the overall harmonic distortion in the voltage supplied by the utility. The voltage and current distortion limits should be used as system design values for the worst case of normal operating conditions lasting more than 1 h. For shorter periods, such as during start-ups, the limits may be exceeded by 50 percent.

This standard divides the responsibility for limiting harmonics between both end users and the utility. End users will be responsible for limiting the harmonic current injections, while the utility will be primarily responsible for limiting voltage distortion in the supply system.

The harmonic current and voltage limits are applied at the PCC. This is the point where other customers share the same bus or where new customers may be connected in the future. The standard seeks a fair approach to allocating a harmonic limit quota for each customer. The standard allocates current injection limits based on the size of the load with respect to the size of the power system, which is defined by its short-circuit capacity. The short-circuit ratio is defined as the ratio of the maximum short-circuit current at the PCC to the maximum demand load current (fundamental frequency component) at the PCC as well.

The basis for limiting harmonic injections from individual customers is to avoid unacceptable levels of voltage distortions. Thus the current limits are developed so that the total harmonic injections from an individual customer do not exceed the maximum voltage distortion shown in Table 4.8. Table 4.8 shows harmonic current limits for various system voltages. Smaller loads (typically larger short-circuit ratio values) are allowed a higher percentage of harmonic currents than larger loads with smaller short-circuit ratio values. Larger loads have to meet more stringent limits since they occupy a larger portion of system load capacity. The current limits take into account the diversity of harmonic currents in which some harmonics tend to cancel out while others are additive. The harmonic current limits at the PCC are developed to limit individual voltage distortion and voltage THD to the values shown in Table 4.1. Since voltage distortion is dependent on the system impedance, the key to controlling voltage distortion is to control the impedance.

The two main conditions that result in high impedance are when the system is too weak to supply the load adequately or the system is in resonance. The latter is more common. Therefore, keeping the voltage distortion low usually means keeping the system out of resonance. Occasionally, new transformers and lines will have to be added to increase the system strength. IEEE Standard 519-1992 represents a consensus of guidelines and recommended practices by the utilities and their customers in minimizing and controlling the impact of harmonics generated by nonlinear loads.

Table 4.8 Basis for Harmonic Current Limits

Short-circuit ratio at PCC	Maximum individual frequency voltage harmonic (%)	Related assumption
10	2.5–3.0	Dedicated system
20	2.0–2.5	1–2 large customers
50	1.0–1.5	A few relatively large customers
100	0.5–1.0	5–20 medium-size customers
1000	0.05–0.10	Many small customers

Overview of IEC standards on harmonics

The International Electro technical Commission (IEC), currently with headquarters in Geneva, Switzerland, has defined a category of electromagnetic compatibility (EMC) standards that deal with power quality issues. The term electromagnetic compatibility includes concerns for both radiated and conducted interference with end-use equipment. The IEC standards are broken down into six parts:

- *Part 1: General.* These standards deal with general considerations such as introduction, fundamental principles, rationale, definitions, and terminologies. They can also describe the application and interpretation of fundamental definitions and terms. Their designation number is IEC 61000-1-x.
- *Part 2: Environment.* These standards define characteristics of the environment where equipment will be applied, the classification of such environment, and its compatibility levels. Their designation number is IEC 61000-2-x.

- *Part 3: Limits.* These standards define the permissible levels of emissions that can be generated by equipment connected to the environment. They set numerical emission limits and also immunity limits. Their designation number is IEC 61000-3-x.
- *Part 4: Testing and measurement techniques.* These standards provide detailed guidelines for measurement equipment and test procedures to ensure compliance with the other parts of the standards. Their designation number is IEC 61000-4-x.
- *Part 5: Installation and mitigation guidelines.* These standards provide guidelines in application of equipment such as earthing and cabling of electrical and electronic systems for ensuring electromagnetic compatibility among electrical and electronic apparatus or systems. They also describe protection concepts for civil facilities against the high-altitude electromagnetic pulse (HEMP) due to high altitude nuclear explosions. They are designated with IEC 61000-5-x.
- *Part 6: Miscellaneous.* These standards are generic standards defining immunity and emission levels required for equipment in general categories or for specific types of equipment.

Their designation number is IEC 61000-6-x. IEC standards relating to harmonics generally fall in parts 2 and 3. Unlike the IEEE standards on harmonics where there is only a single publication covering all issues related to harmonics, IEC standards on harmonics are separated into several publications. There are standards dealing with environments and limits which are further broken down based on the voltage and current levels. These key standards are as follows:

- IEC 61000-2-2 (1993): *Electromagnetic Compatibility (EMC)*. Part 2: Environment. Section 2: Compatibility Levels for Low-Frequency Conducted Disturbances and Signaling in Public Low-Voltage Power Supply Systems.
- IEC 61000-3-2 (2000): *Electromagnetic Compatibility (EMC)*. Part 3: Limits. Section 2: Limits for Harmonic Current Emissions (Equipment Input Current Up to and Including 16 A per Phase).
- IEC 61000-3-4 (1998): *Electromagnetic Compatibility (EMC)*. Part 3: Limits. Section 4: Limitation of Emission of Harmonic Currents in Low-Voltage Power Supply Systems for Equipment with Rated Current Greater Than 16 A.

- IEC 61000-3-6 (1996): *Electromagnetic Compatibility (EMC)*. Part 3: Limits. Section 6: Assessment of Emission Limits for Distorting Loads in MV and HV Power Systems. Basic EMC publication. Prior to 1997, these standards were designated by a 1000 series numbering scheme. For example, IEC 61000-2-2 was known as IEC 1000-2-2. These standards on harmonics are generally adopted by the European Community (CENELEC); thus, they are also designated with the EN 61000 series. For example, IEC 61000-3-2 is also known as EN 61000-3-2.

4.9.2. IEC 61000-2-2

IEC 61000-2-2 defines compatibility levels for low-frequency conducted disturbances and signaling in public low-voltage power supply systems such as 50- or 60-Hz single- and three-phase systems with nominal voltage up to 240 and 415 V, respectively. Compatibility levels are defined empirically such that they reduce the number of complaints of mis operation to an acceptable level.¹⁵ These levels are not rigid and can be exceeded in a few exceptional conditions. Compatibility levels for individual harmonic voltages in the low-voltage network are shown in Table 6.7. They are given in percentage of the fundamental voltage.

4.9.3. IEC 61000-3-2 and IEC 61000-3-4

Both IEC 61000-3-2 and 61000-3-4 define limits for harmonic current emission from equipment drawing input current of up to and including 16 A per phase and larger than 16 A per phase, respectively. These standards are aimed at limiting harmonic emissions from equipment connected to the low-voltage public network so that compliance with the limits ensures that the voltage in the public network satisfies the compatibility limits defined in IEC 61000-2-2. The IEC 61000-3-2 is an outgrowth from IEC 555-2 (EN 60555-2). The standard classifies equipment into four categories:

- Class A: Balanced three-phase equipment and all other equipment not belonging to classes B, C, and D
- Class B: Portable tools.
- Class C: Lighting equipment including dimming devices

- Class D: Equipment having an input current with a “special wave shape” and an active input power of less than 600 W

Figure 4.32 can be used for classifying equipment in IEC 61000-3-2. It should be noted that equipment in classes B and C and provisionally motor-driven equipment are not considered class D equipment regardless of their input current wave shapes. The half-cycle wave shape of class D equipment input current should be within the envelope of the inverted T-shape shown in Fig. 4.33 for at least 95 percent of the time. The center line at $t/2$ lines up with the peak value of the input current I_{pk} . Maximum permissible harmonic currents for classes A, B, C, and D are given in actual amperage measured at the input current of the equipment. Note that harmonic current limits for class B equipment are 150 percent of those in class A. Harmonic current limits according to IEC 61000-3-2 are shown in Tables 6.8 through 6.10. Note that harmonic current limits for class D equipment are specified in absolute numbers and in values relative to active power. The limits only apply to equipment operating at input power up to 600 W. IEC 61000-3-4 limits emissions from equipment drawing input current larger than 16 A and up to 75 A. Connections of this type of equipment do not require consent from the utility. Harmonic current limits based on this standard are shown in Table 4.3.

Table 4.3 Harmonic Current Limits According to IEC 61000-3-4

Harmonic order h	Max. permissible harmonic current* (%)	Harmonic order h	Max. permissible harmonic current* (%)
3	21.6	19	1.1
5	10.7	21	0.6
7	7.2	23	0.9
9	3.8	25	0.8
11	3.1	27	0.6
13	2	29	0.7
15	0.7	31	0.7
17	1.2	33	0.6

*Percent of the fundamental input current.

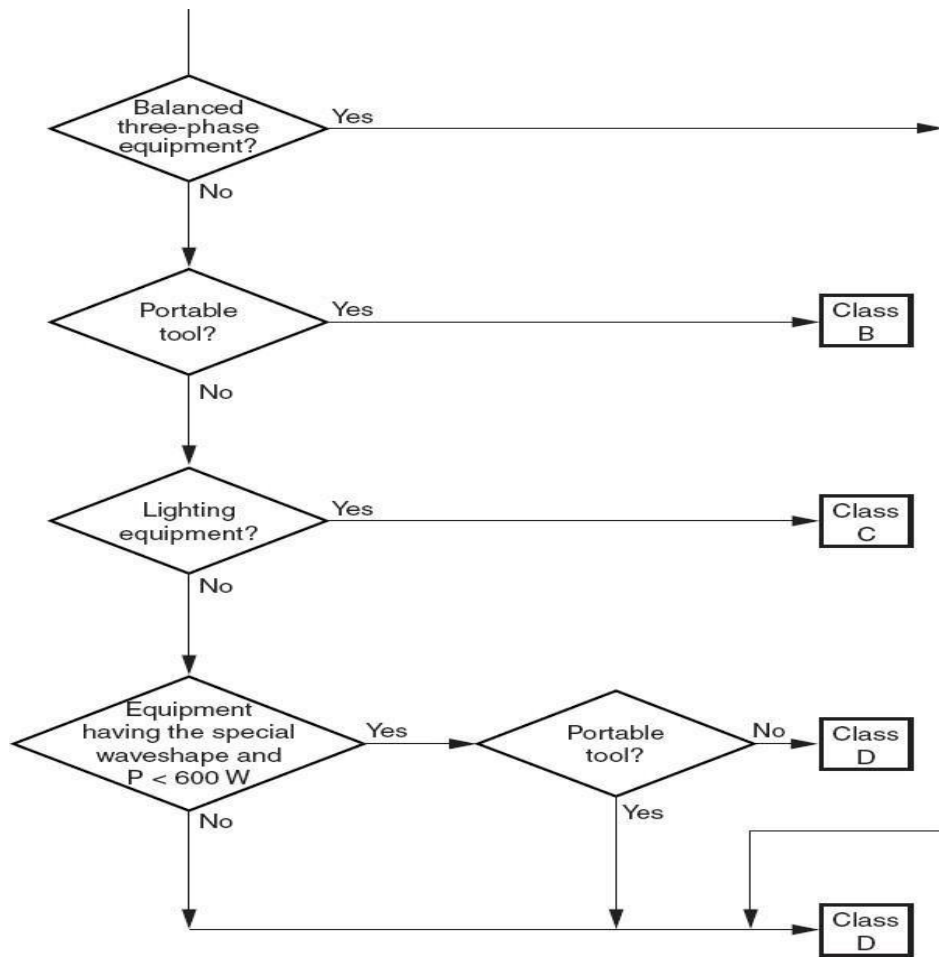

Figure 4.32 Flowchart for classifying equipment according to IEC 61000-3-2.

Unit-5

Power Quality Monitoring

Monitoring Considerations – monitoring and diagnostic techniques for various power quality problems – modeling of power quality problems by mathematical simulation tools – power line disturbance analyzer – quality measurement equipment – harmonic / spectrum analyzer – flicker meters – disturbance analyzer. Applications of expert systems for power quality monitoring.

Introduction

Power quality monitoring is the process of gathering, analyzing, and interpreting raw measurement data into useful information. The process of gathering data is usually carried out by continuous measurement of voltage and current over an extended period. The process of analysis and interpretation has been traditionally performed manually, but recent advances in signal processing and artificial intelligence fields have made it possible to design and implement intelligent systems to automatically analyze and interpret raw data into useful information with minimum human intervention.

Power quality monitoring programs are often driven by the demand for improving the system wide power quality performance. Many industrial and commercial customers have equipment that is sensitive to power disturbances, and, therefore, it is more important to understand the quality of power being provided. Examples of these facilities include computer networking and telecommunication facilities, semiconductor and electronics manufacturing facilities, biotechnology and pharmaceutical laboratories, and financial data-processing centers. Hence, in the last decade many utility companies have implemented extensive power quality monitoring programs.

MONITORING CONSIDERATION

The monitoring objectives often determine the choice of monitoring equipment, triggering thresholds, methods for data acquisition and storage, and analysis and interpretation requirements. Several common objectives of power quality monitoring are summarized here.

Monitoring to characterize system performance:

This is the most general requirement. A power producer may find this objective important if it has the need to understand its system performance and then match that system performance with the needs of customers. System characterization is a proactive approach to power quality monitoring. By understanding the normal power quality performance of a system, a provider can quickly identify problems and can offer information to its customers to help them match their sensitive equipment's characteristics with realistic power quality characteristics.

Monitoring to characterize specific problems:

Many power quality service departments or plant managers solve problems by performing short-term monitoring at specific customer sites or at difficult loads. This is a reactive mode of power quality monitoring, but it frequently identifies the cause of equipment incompatibility, which is the first step to a solution.

Monitoring as part of an enhanced power quality service:

Many power producers are currently considering additional services to offer customers. One of these services would be to offer differentiated levels of power quality to match the needs of specific customers. A provider and customer can together achieve this goal by modifying the power system or by installing equipment within the customer's premises. In either case, monitoring becomes essential to establish the benchmarks for the differentiated service and to verify that the utility achieves contracted levels of power quality.

Monitoring as part of predictive or just-in-time maintenance:

Power quality data gathered over time can be analyzed to provide information relating to specific equipment performance. For example, a repetitive arcing fault from an underground cable may signify impending cable failure, or repetitive capacitor-switching restrikes may signify impending failure on the capacitor-switching device. Equipment maintenance can be quickly ordered to avoid catastrophic failure, thus preventing major power quality disturbances which ultimately will impact overall power quality performance.

The monitoring program must be designed based on the appropriate objectives, and it must make the information available in a convenient form and in a timely manner (i.e.,

immediately). The most comprehensive monitoring approach will be a permanently installed monitoring system with automatic collection of information about steady-state power quality conditions and energy use as well as disturbances.

Monitoring as part of a facility site survey

Site surveys are performed to evaluate concerns for power quality and equipment performance throughout a facility. The survey will include inspection of wiring and grounding concerns, equipment connections, and the voltage and current characteristics throughout the facility. Power quality monitoring, along with infrared scans and visual inspections, is an important part of the overall survey. The initial site survey should be designed to obtain as much information as possible about the customer facility. This information is especially important when the monitoring objective is intended to address specific power quality problems. This information is summarized here.

1. Nature of the problems (data loss, nuisance trips, component failures, control system malfunctions, etc.)
2. Characteristics of the sensitive equipment experiencing problems (equipment design information or at least application guide information)
3. The times at which problems occur
4. Coincident problems or known operations (e.g., capacitor switching) that occur at the same time
5. Possible sources of power quality variations within the facility (motor starting, capacitor switching, power electronic equipment operation, arcing equipment, etc.)
6. Existing power conditioning equipment being used
7. Electrical system data (one-line diagrams, transformer sizes and impedances, load information, capacitor information, cable data, etc.)

Determining what to monitor

Power quality encompasses a wide variety of conditions on the power system. Important disturbances can range from very high frequency impulses caused by lightning strokes or current chopping during circuit interruptions to long-term overvoltages caused by a regulator tap switching problem. The range of conditions that must be characterized creates challenges both in terms of the monitoring equipment performance specifications and in the data-collection requirements. The methods for characterizing the quality of ac power are important for the monitoring requirements. For instance, characterizing most transients requires high-frequency sampling of the actual waveform. Voltage sags can be characterized with a plot of the rms voltage versus time. Outages can be defined simply by a time duration. Monitoring to characterize harmonic distortion levels and normal voltage variations requires steady-state sampling with results analysis of trends over time. Extensive monitoring of all the different types of power quality variations at many locations may be rather costly in terms of hardware, communications charges, data management, and report preparation. Hence, the priorities for monitoring should be determined based on the objectives of the effort. Projects to benchmark system performance should involve a reasonably complete monitoring effort. Projects designed to evaluate compliance with IEEE Standard 519-1992 for harmonic distortion levels may only require steady-state monitoring of harmonic levels. Other projects focused on specific industrial problems may only require monitoring of rms variations, such as voltage sags.

Choosing monitoring locations

Obviously, we would like to monitor conditions at virtually all locations throughout the system to completely understand the overall power quality. However, such monitoring may be prohibitively expensive and there are challenges in data management, analysis, and interpretation. Fortunately, taking measurements from all possible locations is usually not necessary since measurements taken from several strategic locations can be used to determine characteristics of the overall system. Thus, it is very important that the monitoring locations be selected carefully based on the monitoring objectives.

Options for permanent power quality monitoring equipment

Permanent power quality monitoring systems, such as the system illustrated in Fig. 5.1, should take advantage of the wide variety of equipment that may have the capability to record power quality information. Some of the categories of equipment that can be incorporated into an overall monitoring system include the following:

- ✓ **Digital fault recorders (DFRs).** These may already be in place at many substations. DFR manufacturers do not design the devices specifically for power quality monitoring. However, a DFR will typically trigger on fault events and record the voltage and current waveforms that characterize the event. This makes them valuable for characterizing rms disturbances, such as voltage sags, during power system faults. DFRs also offer periodic waveform capture for calculating harmonic distortion levels.
- ✓ **Smart relays and other IEDs.** Many types of substation equipment may have the capability to be an intelligent electronic device (IED) with monitoring capability. Manufacturers of devices like relays and re closers that monitor the current anyway are adding on the capability to record disturbances and make the information available to an overall monitoring system controller. These devices can be located on the feeder circuits as well as at the substation.
- ✓ **Voltage recorders.** Power providers use a variety of voltage recorders to monitor steady-state voltage variations on distribution systems. We are encountering more and more sophisticated models fully capable of characterizing momentary voltage sags and even harmonic distortion levels. Typically, the voltage recorder provides a trend that gives the maximum, minimum, and average voltage within a specified sampling window. With this type of sampling, the recorder can characterize a voltage sag magnitude adequately. However, it will not provide the duration with a resolution less than 2 s.
- ✓ **In-plant power monitors.** It is now common for monitoring systems in industrial facilities to have some power quality capabilities. These monitors, particularly those located at the service entrance, can be used as part of a utility monitoring program. Capabilities usually include wave shape capture for evaluation of harmonic distortion levels, voltage profiles for steady-state rms variations, and triggered waveshape captures for voltage sag conditions. It is not common for these instruments to have transient monitoring capabilities.

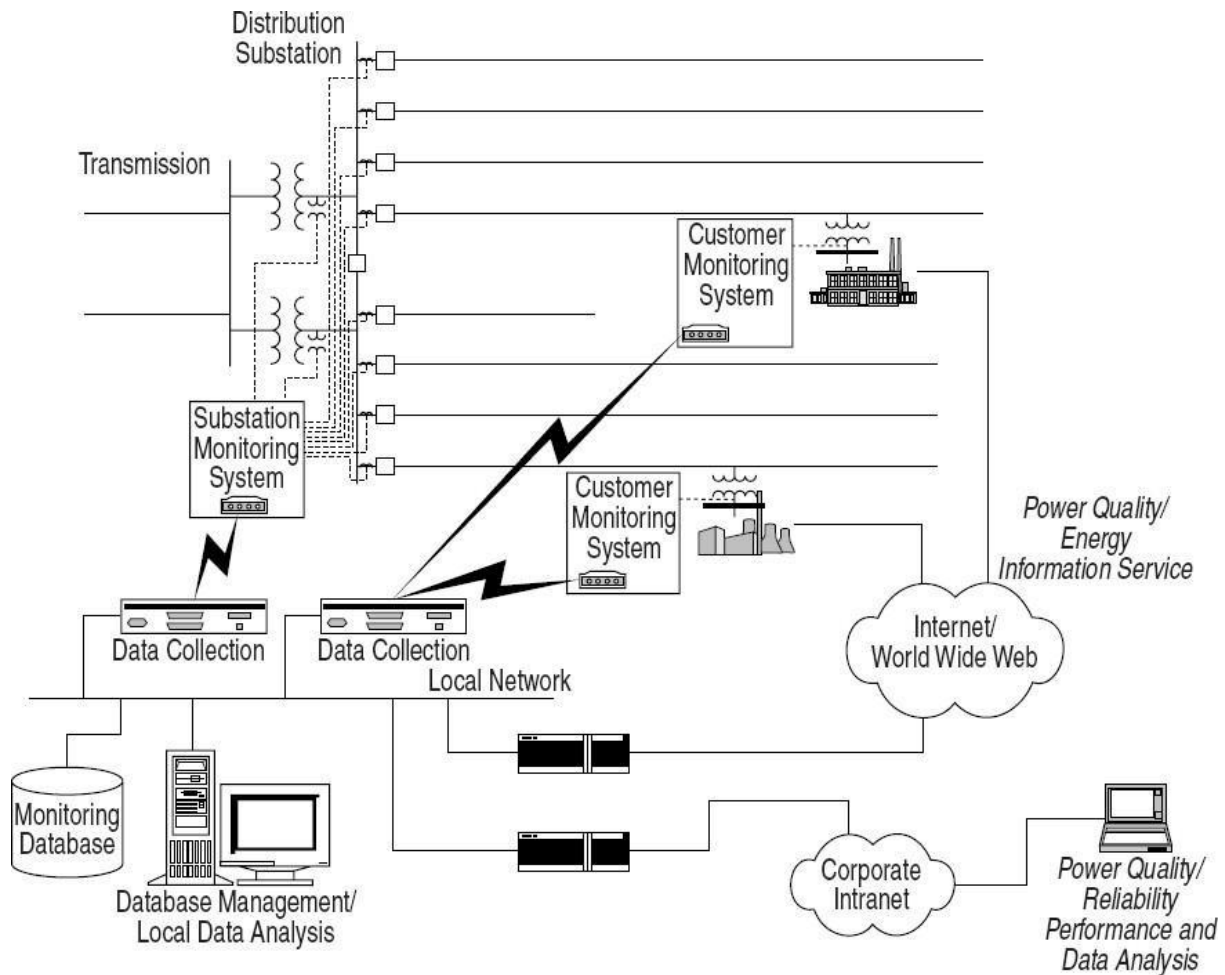

Figure 5.1 Illustration of system power quality monitoring concept with monitoring at the substation and selected customer locations.

Finding the source of a disturbance

The first step in identifying the source of a disturbance is to correlate the disturbance waveform with possible causes. Once a category for the cause has been determined (e.g., load switching, capacitor switching, remote fault condition, recloser operation), the identification becomes more straightforward. The following general guidelines can help:

- High-frequency voltage variations will be limited to locations close to the source of the disturbance. Low-voltage (600 V and below) wiring often damps out high-frequency components very quickly due to circuit resistance, so these frequency components will only appear when the monitor is located close to the source of the disturbance.

- Power interruptions close to the monitoring location will cause a very abrupt change in the voltage. Power interruptions remote from the monitoring location will result in a decaying voltage due to stored energy in rotating equipment and capacitors.
- The highest harmonic voltage distortion levels will occur close to capacitors that are causing resonance problems. In these cases, a single frequency will usually dominate the voltage harmonic spectrum.

POWER QUALITY MEASUREMENT EQUIPMENT

They include everything from very fast transient over voltages (microsecond time frame) to long-duration outages (hours or days time frame). Power quality problems also include steady-state phenomena, such as harmonic distortion, and intermittent phenomena, such as voltage flicker.

Types of instruments

Although instruments have been developed that measure a wide variety of disturbances, a number of different instruments may be used, depending on the phenomena being investigated. Basic categories of instruments that may be applicable include

- Wiring and grounding test devices
- Multimeters
- Oscilloscopes
- Disturbance analyzers
- Harmonic analyzers and spectrum analyzers
- Combination disturbance and harmonic analyzers
- Flicker meters
- Energy monitors

Besides these instruments, which measure steady-state signals or disturbances on the power system directly, there are other instruments that can be used to help solve power quality problems by measuring ambient conditions:

1. Infrared meters can be very valuable in detecting loose connection and overheating conductors. An annual procedure of checking the system in this manner can help prevent power quality problems due to arcing, bad connections, and overloaded conductors.
2. Noise problems related to electromagnetic radiation may require measurement of field strengths in the vicinity of affected equipment. Magnetic gauss meters are used to measure magnetic field strengths for inductive coupling concerns. Electric field meters can measure the strength of electric fields for electrostatic coupling concerns.
3. Static electricity meters are special-purpose devices used to measure static electricity in the vicinity of sensitive equipment. Electrostatic discharge (ESD) can be an important cause of power quality problems in some types of electronic equipment.

Regardless of the type of instrumentation needed for a particular test, there are a number of important factors that should be considered when selecting the instrument. Some of the more important factors include

- Number of channels (voltage and/or current)
- Temperature specifications of the instrument
- Ruggedness of the instrument
- Input voltage range (e.g., 0 to 600 V)
- Power requirements
- Ability to measure three-phase voltages
- Input isolation (isolation between input channels and from each input to ground)
- Ability to measure currents
- Housing of the instrument (portable, rack-mount, etc.)
- Ease of use (user interface, graphics capability, etc.)
- Documentation
- Communication capability (modem, network interface)
- Analysis software

The flexibility (comprehensiveness) of the instrument is also important. The more functions that can be performed with a single instrument, the fewer the number of instruments required

Wiring and grounding testers:

Many power quality problems reported by end users are caused by problems with wiring and/or grounding within the facility. These problems can be identified by visual inspection of wiring, connections, and panel boxes and also with special test devices for detecting wiring and grounding problems.

Important capabilities for a wiring and grounding test device include

- Detection of isolated ground shorts and neutral-ground bonds
- Ground impedance and neutral impedance measurement or indication
- Detection of open grounds, open neutrals, or open hot wires
- Detection of hot/neutral reversals or neutral/ground reversals

Three-phase wiring testers should also test for phase rotation and phase-to-phase voltages. These test devices can be quite simple and provide an excellent initial test for circuit integrity. Many problems can be detected without the requirement for detailed monitoring using expensive instrumentation.

Multimeters:

After initial tests of wiring integrity, it may also be necessary to make quick checks of the voltage and/or current levels within a facility. Overloading of circuits, under voltage and overvoltage problems, and unbalances between circuits can be detected in this manner. These measurements just require a simple multi meter. Signals used to check for these include

- Phase-to-ground voltages
- Phase-to-neutral voltages
- Neutral-to-ground voltages
- Phase-to-phase voltages (three-phase system)
- Phase currents
- Neutral currents

The most important factor to consider when selecting and using a multimeter is the method of calculation used in the meter. All the commonly used meters are calibrated to give an rms indication for the measured signal. However, a number of different methods are used to calculate the rms value. The three most common methods are

1. Peak method. Assuming the signal to be a sinusoid, the meter reads the peak of the signal and divides the result by 1.414 (square root of 2) to obtain the rms.

2. Averaging method. The meter determines the average value of a rectified signal. For a clean sinusoidal signal (signal containing only one frequency), this average value is related to the rms value by a constant.

3. True rms. The rms value of a signal is a measure of the heating that will result if the voltage is impressed across a resistive load. One method of detecting the true rms value is to actually use a thermal detector to measure a heating value. More modern digital meters use a digital calculation of the rms value by squaring the signal on a sample by-sample basis, averaging over the period, and then taking the square root of the result. These different methods all give the same result for a clean, sinusoidal signal but can give significantly different answers for distorted signals. This is very important because significant distortion levels are

Disturbance analyzers

Disturbance analyzers and disturbance monitors form a category of instruments that have been developed specifically for power quality measurements. They typically can measure a wide variety of system disturbances from very short duration transient voltages to long-duration outages or under voltages. Thresholds can be set and the instruments left unattended to record disturbances over a period of time. The information is most commonly recorded on a paper tape, but many devices have attachments so that it can be recorded on disk as well.

There are basically two categories of these devices:

1. Conventional analyzers that summarize events with specific information such as overvoltage and undervoltage magnitudes, sags and surge magnitude and duration, transient magnitude and duration, etc.

2. Graphics-based analyzers that save and print the actual waveform along with the descriptive information which would be generated by one of the conventional analyzers

It is often difficult to determine the characteristics of a disturbance or a transient from the summary information available from conventional disturbance analyzers. For instance, an oscillatory transient cannot be effectively described by a peak and a duration. Therefore, it is almost imperative to have the waveform capture capability of a graphics-based disturbance analyzer for detailed analysis of a power quality problem (Fig. 5.2). However, a simple conventional disturbance monitor can be valuable for initial checks at a problem location.

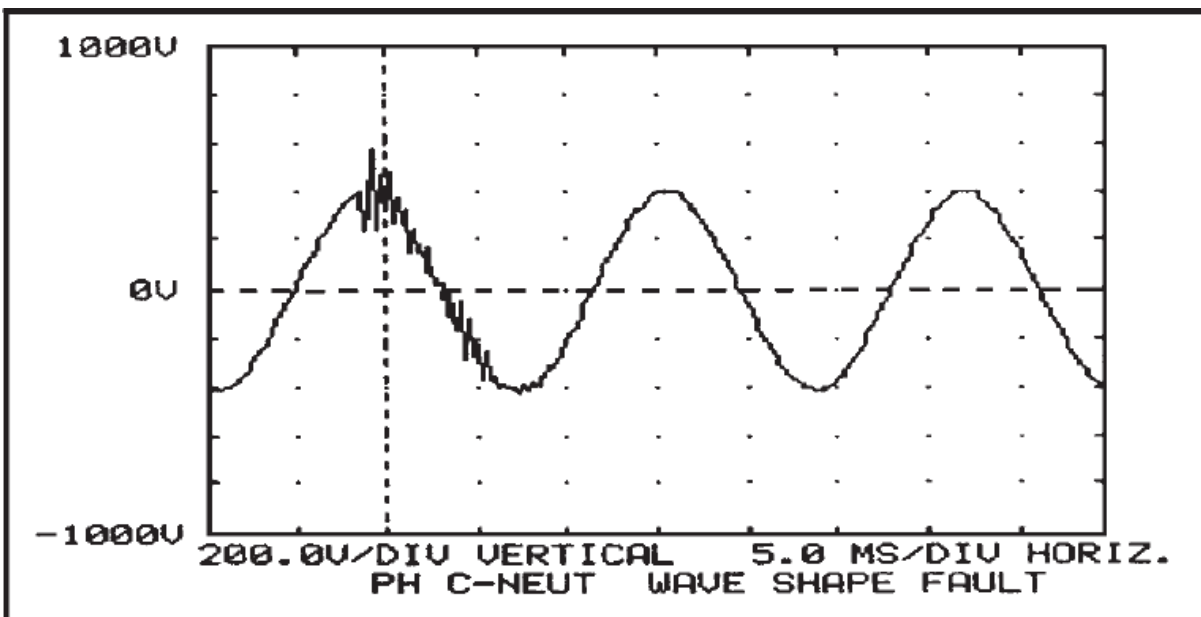

Figure 5.2 Graphics-based analyzer output.

Spectrum analyzers and harmonic analyzers

Harmonic analyzers have several capabilities. They capture harmonic waveforms and display them on a screen. They calculate the K factor to de rate transformers and the total harmonic distortion (THD) in percent of the fundamental. They also measure the corresponding

frequency spectrum, i.e., the harmonic frequency associated with the current and voltage up to the fiftieth harmonic.

They display the harmonic frequency on a bar graph or as the signal's numerical values. Some measure single-phase current and voltage while others measure three-phase current and voltage. All of them measure the power factor (PF). The power factor provides a measurement of how much of the power is being used efficiently for useful work. Some can store data for a week or more for later transfer to a PC for analysis.

This makes them powerful tools in the analysis of harmonic power quality problems. Some of the more powerful analyzers have add-on modules that can be used for computing fast Fourier transform (FFT) calculations to determine the lower-order harmonics. However, any significant harmonic measurement requirements will demand an instrument that is designed for spectral analysis or harmonic analysis. Important capabilities for useful harmonic measurements include Capability to measure both voltage and current simultaneously so that harmonic power flow information can be obtained.

- Capability to measure both magnitude and phase angle of individual harmonic components (also needed for power flow calculations).
- Synchronization and a sampling rate fast enough to obtain accurate measurement of harmonic components up to at least the 37th harmonic (this requirement is a combination of a high sampling rate and a sampling interval based on the 60-Hz fundamental).
- Capability to characterize the statistical nature of harmonic distortion levels (harmonics levels change with changing load conditions and changing system conditions).

There are basically three categories of instruments to consider for harmonic analysis:

1. Simple meters. It may sometimes be necessary to make a quick check of harmonic levels at a problem location. A simple, portable meter for this purpose is ideal. There are now several hand-held instruments of this type on the market. Each instrument has advantages and disadvantages in its operation and design. These devices generally use microprocessor-based circuitry to perform the necessary calculations to determine individual harmonics up to the 50th harmonic, as well as the rms, the THD, and the telephone influence factor (TIF). Some of these

devices can calculate harmonic powers (magnitudes and angles) and can upload stored waveforms and calculated data to a personal computer.

2. General-purpose spectrum analyzers. Instruments in this category are designed to perform spectrum analysis on waveforms for a wide variety of applications. They are general signal analysis instruments. The advantage of these instruments is that they have very powerful capabilities for a reasonable price since they are designed for a broader market than just power system applications. The disadvantage is that they are not designed specifically for sampling power frequency waveforms and, therefore, must be used carefully to assure accurate harmonic analysis. There are a wide variety of instruments in this category.

3. Special-purpose power system harmonic analyzers. Besides the general-purpose spectrum analyzers just described, there are also a number of instruments and devices that have been designed specifically for power system harmonic analysis. These are based on the FFT with sampling rates specifically designed for determining harmonic components in power signals. They can generally be left in the field and include communications capability for remote monitoring.

Flicker meters

Over the years, many different methods for measuring flicker have been developed. These methods range from using very simple rms meters with flicker curves to elaborate flicker meters that use exactly tuned filters and statistical analysis to evaluate the level of voltage flicker. This section discusses various methods available for measuring flicker.

Flicker standards. Although the United States does not currently have a standard for flicker measurement, there are IEEE standards that address flicker. IEEE Standards 141-19936 and 519-19927 both contain flicker curves that have been used as guides for utilities to evaluate the severity of flicker within their system. Both flicker curves, from Standards 141 and 519, are shown in Fig. 5.3. In other countries, a standard methodology for measuring flicker has been established. The IEC flicker meter is the standard for measuring flicker in Europe and other countries currently adopting IEC standards. The IEC method for flicker measurement, defined in IEC Standard 61000-4-158 (formerly IEC 868), is a very comprehensive approach to flicker measurement and is further described in “Flicker Measurement Techniques” below. More

recently, the IEEE has been working toward adoption of the IEC flicker monitoring standards with an additional curve to account for the differences between 230-V and 120-V systems.

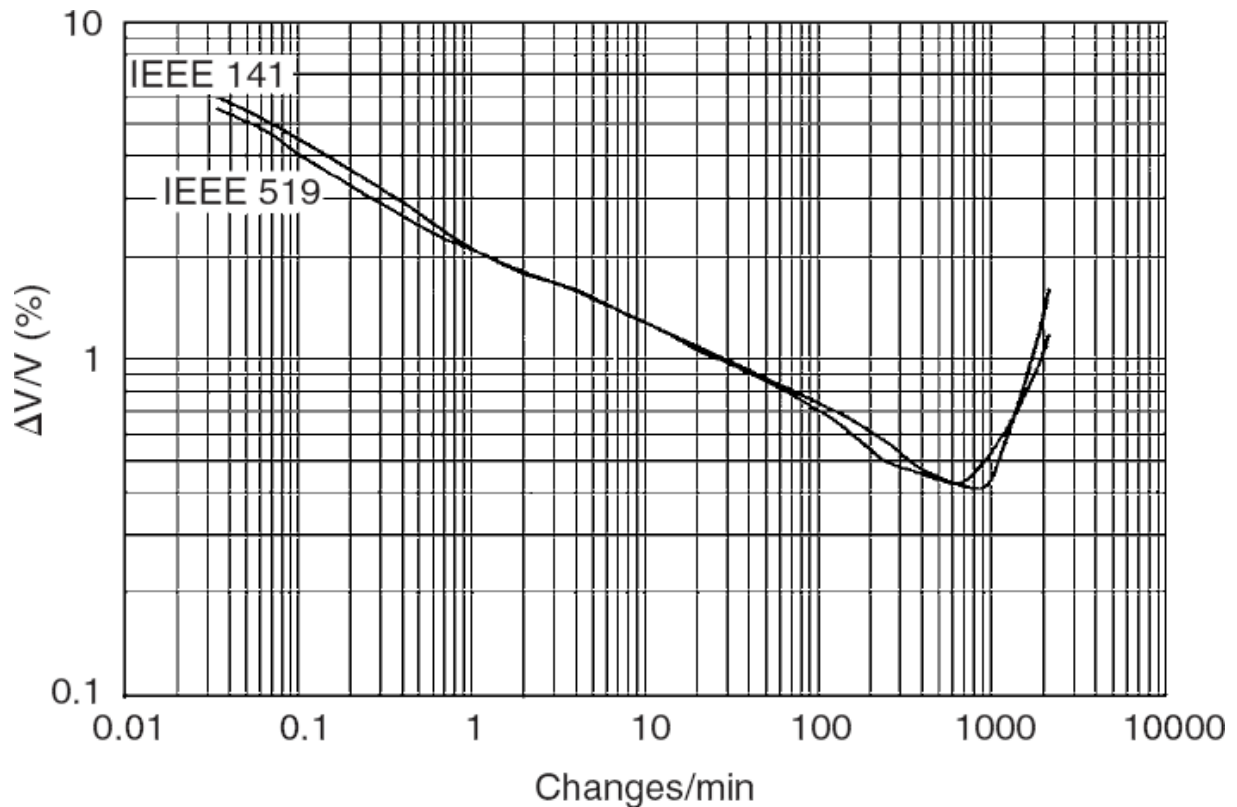

Figure 5.3 Flicker curves from IEEE Standards 141 and 519.

Flicker measurement techniques

RMS strip charts. Historically, flicker has been measured using rms meters, load duty cycle, and a flicker curve. If sudden rms voltage deviations occurred with specified frequencies exceeding values found in flicker curves, such as one shown in Fig. 5.3, the system was said to have experienced flicker. A sample graph of rms voltage variations is shown in Fig. 5.4 where large voltage deviations up to 9.0 V rms ($\Delta V/V \pm 8.0$ percent on a 120-V base) are found. Upon comparing this to the flicker curve in Fig. 5.3, the feeder would be experiencing flicker, regardless of the duty cycle of the load producing the flicker, because any sudden total change in voltage greater than 7.0 V rms results in objectionable flicker, regardless of the frequency. The advantage to such a method is that it is quite simple in nature and the rms data required are rather easy to acquire. The apparent disadvantage to such a method would be the lack of accuracy and inability to obtain the exact frequency content of the flicker.

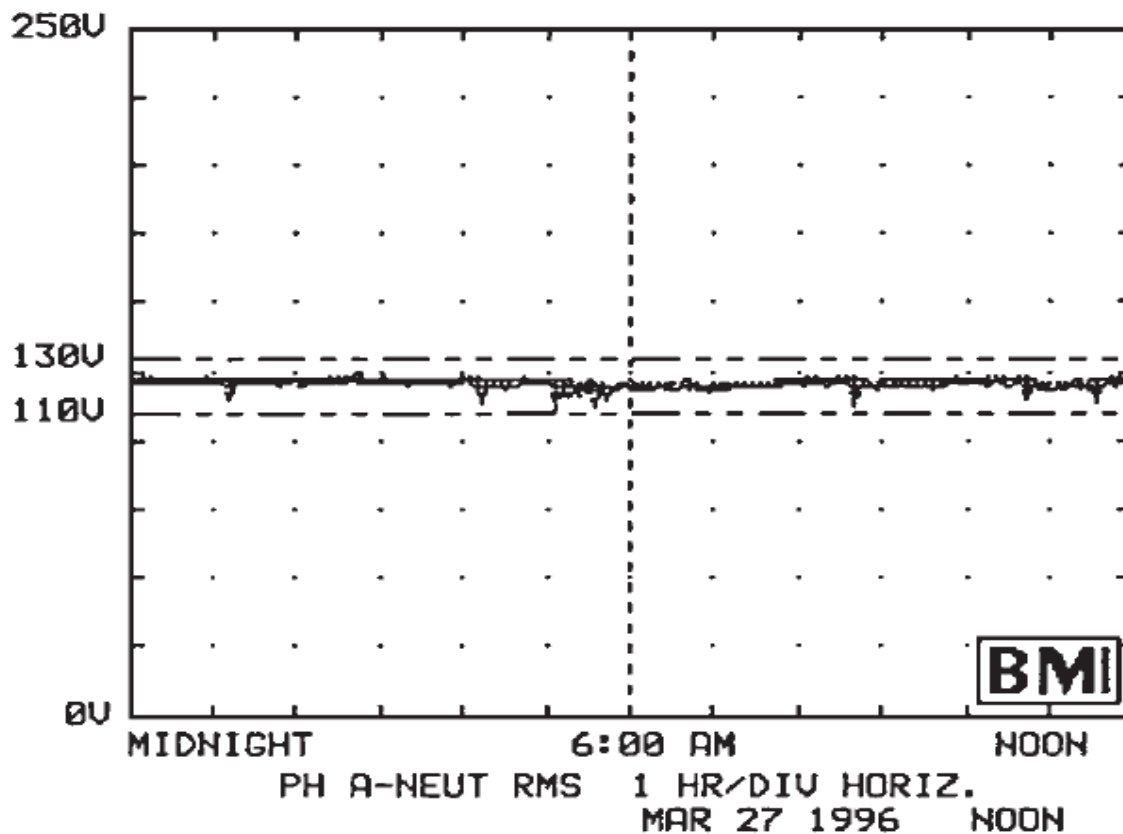

Figure 5.4 RMS voltage variations.

Fast Fourier transforms. Another method that has been used to measure flicker is to take raw samples of the actual voltage waveforms and implement a fast Fourier transform on the demodulated signal (flicker signal only) to extract the various frequencies and magnitudes found in the data. These data would then be compared to a flicker curve. Although similar to using the rms strip charts, this method more accurately quantifies the data measured due to the magnitude and frequency of the flicker being known. The downside to implementing this method is associated with quantifying flicker levels when the flicker-producing load contains multiple flicker signals. Some instruments compensate for this by reporting only the dominant frequency and discarding the rest.

Flicker meters. Because of the complexity of quantifying flicker levels that are based upon human perception, the most comprehensive approach to measuring flicker is to use flicker meters. A flicker meter is essentially a device that demodulates the flicker signal, weights it according to established “flicker curves,” and performs statistical analysis on the processed data.

Generally, these meters can be divided up into three sections. In the first section the input waveform is demodulated, thus removing the carrier signal. As a result of the demodulator, a dc offset and higher-frequency terms (sidebands) are produced. The second section removes these unwanted terms using filters, thus leaving only the modulating (flicker) signal remaining. The second section also consists of filters that weight the modulating signal according to the particular meter specifications. The last section usually consists of a statistical analysis of the measured flicker.

The most established method for doing this is described in IEC Standard 61000-4-15.8. The IEC flicker meter consists of five blocks, which are shown in Fig. 5.5.

Block 1 is an input voltage adapter that scales the input half-cycle rms value to an internal reference level. This allows flicker measurements to be made based upon a percent ratio rather than be dependent upon the input carrier voltage level.

Block 2 is simply a squaring demodulator that squares the input to separate the voltage fluctuation (modulating signal) from the main voltage signal (carrier signal), thus simulating the behavior of the incandescent lamp.

Block 3 consists of multiple filters that serve to filter out unwanted frequencies produced from the demodulator and also to weight the input signal according to the incandescent lamp eye-brain response. The basic transfer function for the weighting filter is

$$H(s) = \frac{k\omega_1 s}{s^2 + 2\lambda s + \omega_1^2} \cdot \frac{1 + s/\omega_2}{(1 + s/\omega_3)(1 + s/\omega_4)} \quad (5.1)$$

Block 4 consists of a squaring multiplier and sliding mean filter. The voltage signal is squared to simulate the nonlinear eye-brain response, while the sliding mean filter averages the signal to simulate the short-term storage effect of the brain. The output of this block is considered to be the instantaneous flicker level. A level of 1 on the output of this block corresponds to perceptible flicker.

Block 5 consists of a statistical analysis of the instantaneous flicker level. The output of block 4 is divided into suitable classes, thus creating a histogram. A probability density function is created based upon each class, and from this a cumulative distribution function can be formed.

Flicker level evaluation can be divided into two categories, short term and long-term. Short-term evaluation of flicker severity PST is based upon an observation period of 10 min. This period is based upon assessing disturbances with a short duty cycle or those that produce continuous fluctuations. PST can be found using the equation

$$P_{ST} = \sqrt{0.0314P_{0.1} + 0.0525P_{1s} + 0.0657P_{3s} + 0.28P_{10s} + 0.08P_{50s}} \quad (5.2)$$

where the percentages P0.1, P1s, P3s, P10s, and P50s are the flicker levels that are exceeded 0.1, 1.0, 3.0, 10.0, and 50.0 percent of the time, respectively. These values are taken from the cumulative distribution curve discussed previously. A PST of 1.0 on the output of block 5 represents the objectionable (or irritable) limit of flicker.

For cases where the duty cycle is long or variable, such as in arc furnaces, or disturbances on the system that are caused by multiple loads operating simultaneously, the need for the long-term assessment of flicker severity arises. Therefore, the long-term flicker severity PLT is derived from PST using the equation

$$R_{LT} = \sqrt[3]{\frac{\sum_{i=1}^N P_{STi}^3}{N}} \quad (5.3)$$

where N is the number of PST readings and is determined by the duty cycle of the flicker-producing load. The purpose is to capture one duty cycle of the fluctuating load. If the duty cycle is unknown, the recommended number of PST readings is 12 (2-h measurement window). The advantage of using a single quantity, like Pst, to characterize flicker is that it provides a basis for implementing contracts and describing flicker levels in a much simpler manner. Figure 11.19 illustrates the Pst levels measured at the PCC with an arc furnace over a 24-h period. The melt cycles when the furnace was operating can be clearly identified by the

high Pst levels. Note that Pst levels greater than 1.0 are usually considered to be levels that might result in customers being aware of lights flickering.

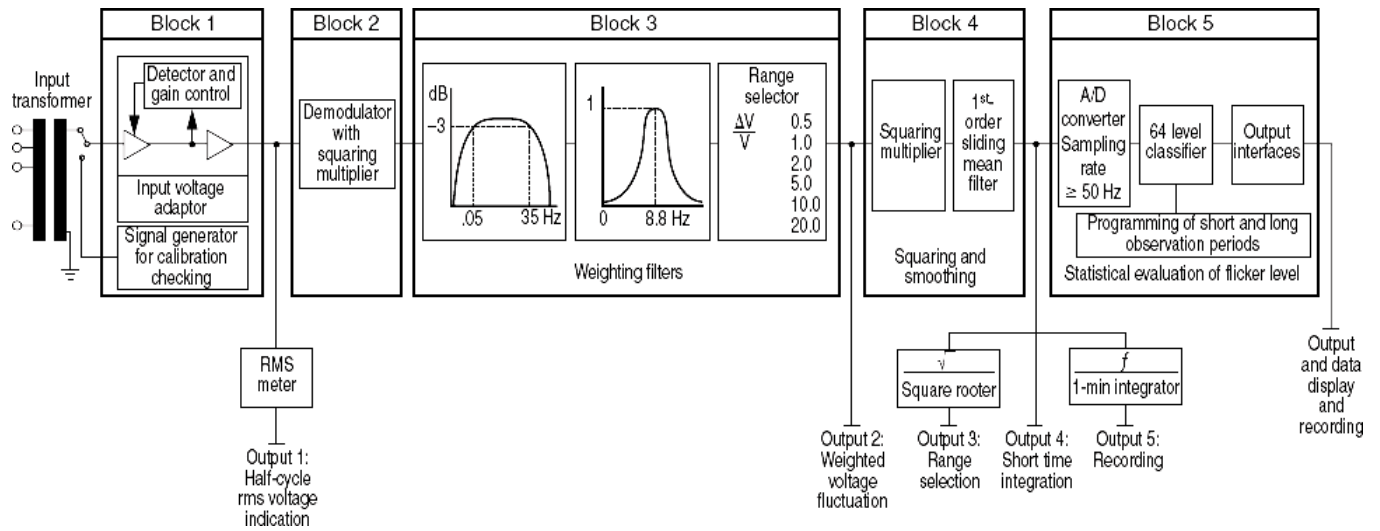

Figure 5.5 Diagram of the IEC flicker meter.

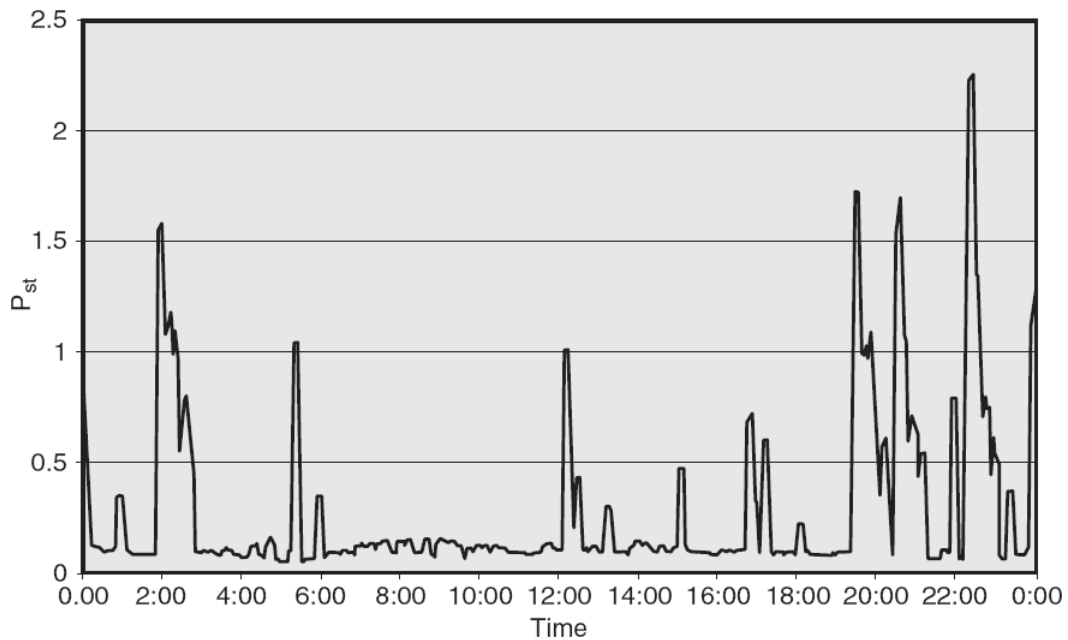

Figure 5.6 Flicker variations at the PCC with an arc furnace characterized by the Pst levels for a 24-h period (March 1, 2001) (note that there is one Pst value every 10 min).

Application of Expert Systems for power quality monitoring

Many advanced power quality monitoring systems are equipped with either off-line or on-line intelligent systems to evaluate disturbances and system conditions so as to make conclusions about the cause of the problem or even predict problems before they occur. The applications of intelligent systems or autonomous expert systems in monitoring instruments help engineers determine the system condition rapidly. This is especially important when restoring service following major disturbances.

The implementation of intelligent systems within a monitoring instrument can significantly increase the value of a monitoring application since it can generate information rather than just collect data.¹¹ The intelligent systems are packaged as individual autonomous expert system modules, where each module performs specific functions. Examples include an expert system module that analyzes capacitors switching transients and determines the relative location of the capacitor bank, and an expert system module to determine the relative location of the fault causing voltage sag.

Basic design of an expert system for monitoring applications

The development of an autonomous expert system calls for many approaches such as signal processing and rule-based techniques along with the knowledge-discovery approach commonly known as data mining. Before the expert system module is designed, the functionalities or objectives of the module must be clearly defined. In other words, the designers or developers of the expert system module must have a clear understanding about what knowledge they are trying to discover from volumes of raw measurement data. This is very important since they will ultimately determine the overall design of the expert system module.

The process of turning raw measurement data into knowledge involves data selection and preparation, information extraction from selected data, information assimilation, and report presentation. These steps (illustrated in Fig. 5.7) are commonly known as knowledge discovery or data mining.

The first step in the knowledge discovery is to select appropriate measurement quantities and disregard other types of measurement that do not provide relevant information. In addition, during the data selection process preliminary analyses are usually carried out to ensure the

quality of the measurement. For example, an expert system module is developed to retrieve a specific answer, and it requires measurements of instantaneous three-phase voltage and current waveforms to be available.

The data-selection task is responsible for ensuring that all required phase voltage and current waveform data are available before proceeding to the next step. In some instances, it might be necessary to interpolate or extrapolate data in this step. Other preliminary examinations include checking any outlier magnitudes, missing data sequences, corrupted data, etc. Examination on data quality is important as the accuracy of the knowledge discovered is determined by the quality of data.

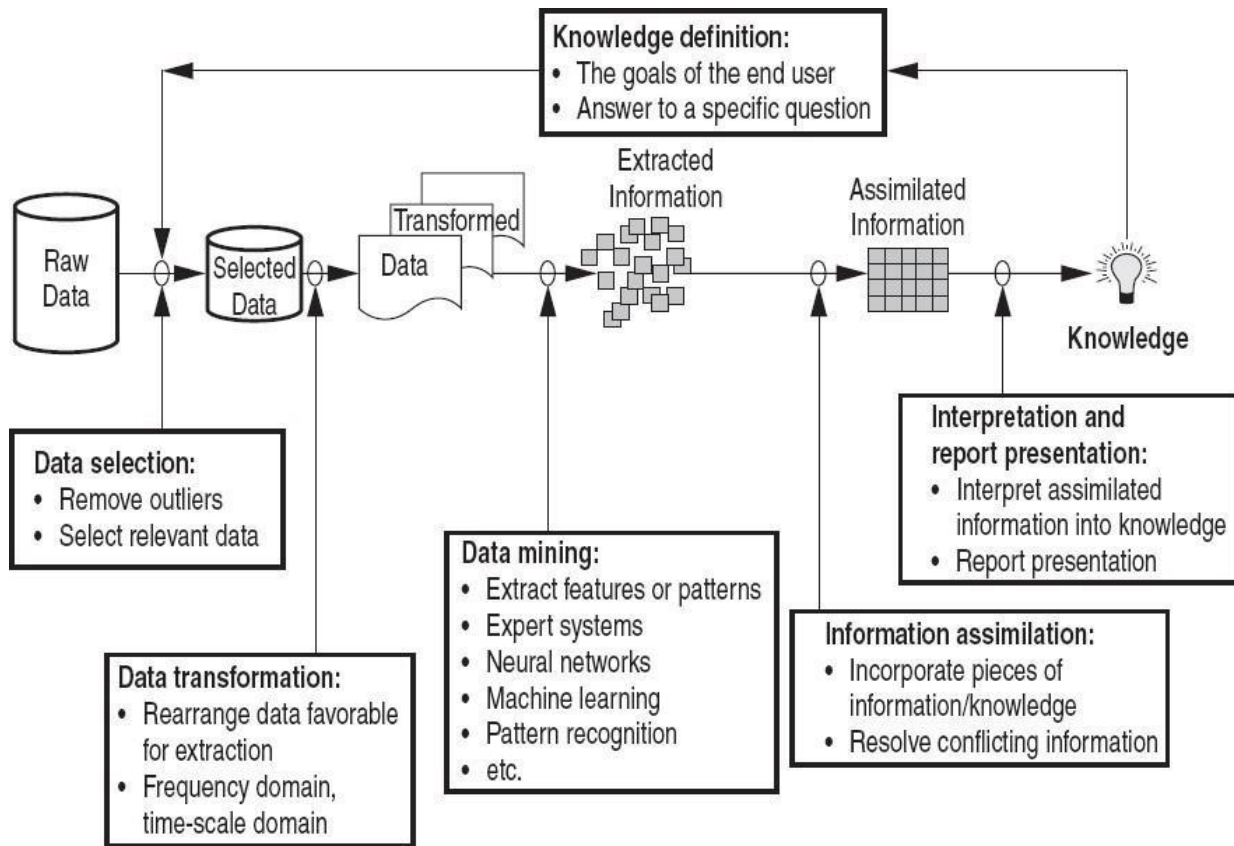

Figure 5.7 Process of turning raw data into answers or knowledge.

The second step attempts to represent the data and project them onto domains in which a solution is more favorable to discover. Signal-processing techniques and power system analysis

are applied. An example of this step is to transform data into another domain where the information might be located. The Fourier transform is performed to uncover frequency information for steady-state signals, the wavelet transform is performed to find the temporal and frequency information for transient signals, and other transforms may be performed as well.

Now that the data are already projected onto other spaces or domains, we are ready to extract the desired information. Techniques to extract the information vary from sophisticated ones, such as pattern recognition, neural networks, and machine learning, to simple ones, such as finding the maximum value in the transformed signal or counting the number of points in which the magnitude of a voltage waveform is above a predetermined threshold value. One example is looking for harmonic frequencies of a distorted waveform. In the second step the waveform is transformed using the Fourier transform, resulting in a frequency domain signal.

A simple harmonic frequency extraction process might be accomplished by first computing the noise level in the frequency domain signal, and subsequently setting a threshold number to several fold that of the noise level. Any magnitude higher than the threshold number may indicate the presence of harmonic frequencies.

The data mining step usually results in scattered pieces of information. These pieces of information are assimilated to form knowledge. In some instances assimilation of information is not readily possible since some pieces of information conflict with each other. If the conflicting information cannot be resolved, the quality of the answer provided might have limited use. The last step in the chain is interpretation of knowledge and report presentation.

Example applications of expert systems

One or more autonomous expert system modules can be implemented within an advanced power quality monitoring system. When a power quality event is captured, all modules will be invoked. Each module will attempt to discover the unique knowledge it is designed to look for. Once the unique knowledge is discovered, the knowledge will be available for users to inspect. The knowledge can be viewed on a standard browser, or sent as an e-mail, pager, or fax message. We present a few examples of autonomous expert systems.

Voltage sag direction module, Voltage sags are some of the most important disturbances on utility systems. They are usually caused by a remote fault somewhere on the power system;

however, they can also be caused by a fault inside end-user facilities. Determining the location of the fault causing the voltage sag can be an important step toward preventing voltage sags in the future and assigning responsibility for addressing the problem. For instance, understanding the fault location is necessary for implementing contracts that include voltage sag performance specifications. The supplier would not be responsible for sags that are caused by faults within the customer facility. This is also important when trying to assess performance of the distribution system in comparison to the transmission system as the cause of voltage sag events that can impact customer operations. The fault locations can help identify future problems or locations where maintenance or system changes are required. An expert system to identify the fault location (at least upstream or downstream from the monitoring location) can help in all these cases.

An autonomous expert system module called the voltage sag direction module is designed just for that purpose, i.e., to detect and identify a voltage sag event and subsequently determine the origin (upstream or downstream from the monitoring location) of the voltage sag event. If a data acquisition node is installed at a customer PCC, the source of the voltage sag will be either on the utility or the customer side of the meter. If the monitoring point is at a distribution substation transformer, the source of the voltage sag will be either the distribution system or the transmission system.

The voltage sag direction module works by comparing current and voltage rms magnitudes both before and after the sag event. It tracks phase angle changes from pre-fault to post-fault. By assembling information from the rms magnitude comparison and the phase angle behavior, the origin of the voltage sag event can be accurately determined. In addition, the voltage sag direction module is equipped with algorithms to assess the quality of the knowledge or answer discovered. If the answer is deemed accurate, it will be sent as an output; otherwise, it will be neglected and no answer will be provided. In this way, inaccurate or false knowledge can be minimized. Inaccurate knowledge can be due to a number of factors, primarily to missing data and unresolved conflicting characteristics.

Outputs of the voltage sag direction module can be displayed on a computer screen using Web browser software, displayed in printed paper format, sent to a pager, or sent as an e-mail. Figure 5.8 shows an output of a voltage sag direction expert system module. The first column indicates the event time, the second column indicates the monitor identification, the third column

indicates event types, the fourth column indicates the triggered channel, and finally the fifth column indicates the characteristics of the event and outputs of the answer module.

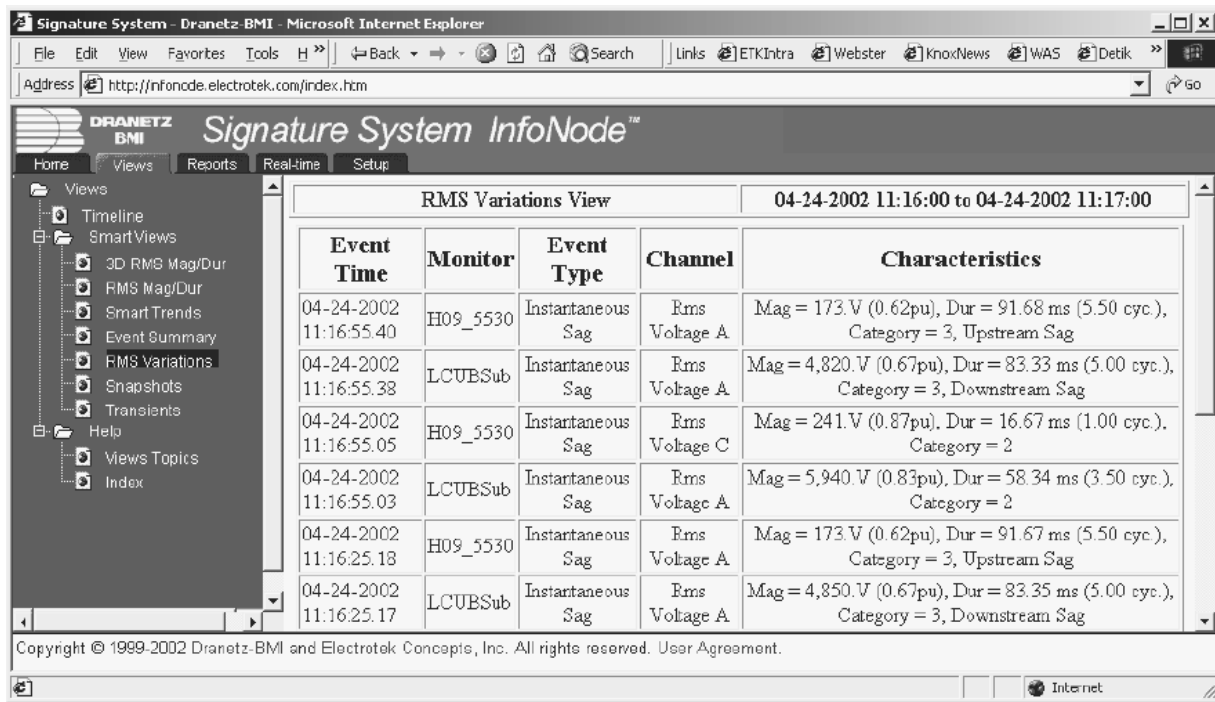

Figure 5.8 A standard Web browser is the interface between the monitoring system and users. Outputs of the voltage sag direction module are shown in the last column of the table.

Figure 5.9 shows an event table with several voltage sag events that occurred at 11:16:55 A.M. on April 24, 2002. A tree branch that fell across a 13-kV overhead line caused the sag events. A total of five automatic re closure operations were performed before the breaker finally tripped and locked out. There were two data acquisition nodes available to capture this disturbance: one at the substation, i.e., at the secondary of 161/13-kV transformer (LCUBSub), where the affected overhead line was served, and one at the service entrance of a Electrotek office complex (H09_5530) located about 0.5 mi from the substation. Obviously, the LCUBSub and H09_5530 data acquisition nodes should report that the directions or the relative origin of voltage sags are downstream and upstream, respectively. Analysis provided by the voltage sag direction module reports the direction of the voltage sag correctly. Note that there are two voltage sag events where the module does not provide any knowledge about the origin of the sag

event. This happens since the algorithms were unable to resolve conflicting characteristics extracted from the data.

The screenshot shows a web browser window titled "RMS Variations View - Microsoft Internet Explorer". The main content is a table with the following columns: Event Time, Monitor, Event Type, Channel, and Characteristics. The table lists ten events, all of which are "Instantaneous Sag" events. The events are categorized as "Upstream Sag" or "Downstream Sag" and are associated with either monitor "H09_5530" or "LCUBSub". The characteristics for each event include magnitude (Mag), duration (Dur), and category (Category).

RMS Variations View		04-24-2002 11:16:00 to 04-24-2002 11:17:00		
Event Time	Monitor	Event Type	Channel	Characteristics
04-24-2002 11:16:55.40	H09_5530	Instantaneous Sag	Rms Voltage A	Mag = 173.V (0.62pu), Dur = 91.68 ms (5.50 cyc.), Category = 3, Upstream Sag
04-24-2002 11:16:55.38	LCUBSub	Instantaneous Sag	Rms Voltage A	Mag = 4,820.V (0.67pu), Dur = 83.33 ms (5.00 cyc.), Category = 3, Downstream Sag
04-24-2002 11:16:55.05	H09_5530	Instantaneous Sag	Rms Voltage C	Mag = 241.V (0.87pu), Dur = 16.67 ms (1.00 cyc.), Category = 2
04-24-2002 11:16:55.03	LCUBSub	Instantaneous Sag	Rms Voltage A	Mag = 5,940.V (0.83pu), Dur = 58.34 ms (3.50 cyc.), Category = 2
04-24-2002 11:16:25.18	H09_5530	Instantaneous Sag	Rms Voltage A	Mag = 173.V (0.62pu), Dur = 91.67 ms (5.50 cyc.), Category = 3, Upstream Sag
04-24-2002 11:16:25.17	LCUBSub	Instantaneous Sag	Rms Voltage A	Mag = 4,850.V (0.67pu), Dur = 83.35 ms (5.00 cyc.), Category = 3, Downstream Sag
04-24-2002 11:16:07.42	H09_5530	Instantaneous Sag	Rms Voltage A	Mag = 173.V (0.62pu), Dur = 91.66 ms (5.50 cyc.), Category = 3, Upstream Sag
04-24-2002 11:16:07.40	LCUBSub	Instantaneous Sag	Rms Voltage A	Mag = 4,850.V (0.67pu), Dur = 83.33 ms (5.00 cyc.), Category = 3, Downstream Sag
04-24-2002 11:16:06.46	H09_5530	Instantaneous Sag	Rms Voltage A	Mag = 174.V (0.63pu), Dur = 91.68 ms (5.50 cyc.), Category = 3, Upstream Sag
04-24-2002 11:16:06.44	LCUBSub	Instantaneous Sag	Rms Voltage A	Mag = 4,840.V (0.67pu), Dur = 83.33 ms (5.00 cyc.), Category = 3, Downstream Sag

Figure 5.9 An event summary report detailing time of occurrence and event characteristics. There are five voltage sag events associated with the autoreclosure operation following a fault. The voltage sag direction module identifies the origin of the sag correctly.

Radial fault locator module. Radial distribution feeders are susceptible to various short-circuit events such as symmetrical faults (three-phase) and unsymmetrical faults, including single-line-to-ground, double line-to-ground, and line-to-line faults. These system faults arise from various conditions ranging from natural causes such as severe weather conditions and animal contacts to

human intervention and errors, including equipment failure. Quickly identifying the source and location of faults is the key to cost-efficient system restoration. The current practice to locate the faults is to send a lineperson to patrol the suspected feeders. While this is a proven method, it is certainly not a cost effective way to restore power.

An expert system module called the radial fault locator is developed to estimate the distance to a fault location from the location where the measurements were made. The unique feature of this module is that it only requires a set of three-phase voltages and currents from a single measurement location with the sequence impedance data of the primary distribution feeder. The module works by first identifying a permanent fault event based on the ground fault and phase fault pickup current threshold. Once a permanent fault event is identified, the distance to fault estimation is carried out based on the apparent impedance approach.¹³ Estimates of the distance to the fault are then displayed in a computer screen with the Web browser or sent to a lineperson via a pager. The lineperson can quickly pinpoint the fault location. This example illustrates the emerging trend in smart power quality monitoring, i.e., collect power quality data and extract and formulate information for users to perform necessary actions.

Capacitor-switching direction module. Capacitor-switching operations are the most common cause of transient events on the power system. When a capacitor bank is energized, it interacts with the system inductance, yielding oscillatory transients. The transient over voltage in an uncontrolled switching is between 1.0 to 2.0 pu with typical over voltages of 1.3 to 1.4 pu and frequencies of 250 to 1000 Hz. Transients due to energizing utility capacitor banks can propagate into customer facilities. Common problems associated with the switching transients include tripping off sensitive equipment such adjustable-speed drives and other electronically controlled loads. Some larger end-user facilities may also have capacitor banks to provide reactive power and voltage support as well. When a sensitive load trips off due to capacitor-switching transients, it is important to know where the capacitor bank is, whether it is on the utility side or in the customer facility. A capacitor-switching direction expert system module is designed to detect and identify a capacitor switching event and determine the relative location of the capacitor bank from the point where measurements were collected. It only requires a set of three-phase voltages and currents to perform the tasks mentioned. This module is useful to determine the responsible parties, i.e., the utility or customer, and help engineers pinpoint the problematic capacitor bank.

The capacitor-switching transient direction module works as follows. When an event is captured, the module will extract the information and represent it in domains where detection and identification are more favorable. The domains where the information is represented are in the time-, frequency-, and time-scale (wavelet) domains. If the root cause of the event is due to a capacitor bank energization, the answer module will proceed to determine the most probable location of the capacitor bank.

There are only two possible locations with respect to the monitoring location, i.e., upstream or downstream. The expert system module works well with grounded, ungrounded, delta-configured, and wye- (or star-) configured capacitor banks. It also works well for back-to-back capacitor banks. The capacitor-switching transient direction module is equipped with algorithms to determine the quality of the information it discovers. Thus, the module may provide an undetermined answer. This answer is certainly better than an incorrect one. An example application of the answer module to analyze data capture from a data acquisition node installed at an office complex service entrance is shown in Fig. 5.6. The analysis results are ,which is a screen capture from a standard Web browser. Since the office complex has no capacitor banks, any capacitor-switching transients must originate from the utility side located upstream from the data acquisition node. The module correctly determines the relative location of the capacitor bank. Note that there are some instances where the expert system was not able to determine the relative location of the capacitor bank. From the time stamp of the events, it is clear that capacitor bank energizations occur at about 5:00 A.M. and 7:00 P.M. each day.

Capacitor-switching operation inspection module. As described, capacitor switching transients are the most common cause of transient events on the power system and are results of capacitor bank energization operation. One common thing that can go wrong with a capacitor bank is for a fuse to blow. Some capacitor banks may not be operating properly for months before utility personnel notice the problem. Routine maintenance is usually performed by driving along the line and visually inspecting the capacitor bank.

An autonomous expert system was developed for substation applications to analyze downstream transient data and determine if a capacitor- switching operation is performed successfully and display a warning message if the operation was not successful.¹⁴ With the large number of capacitor banks on most power systems, this expert system module can be a

significant benefit to power systems engineers in identifying problems and correlating them with capacitor-switching events.

Successful capacitor bank energization is characterized by a uniform increase of kvar on each phase whose total corresponds to the capacitor kvar size. For example, when a 1200-kvar capacitor bank is energized, reactive power of approximately 400 kvar should appear on each phase. The total kvar increase can be determined by computing kvar changes in individual phases from the current and voltage waveforms before and after the switching operation. This total computed kvar change is then compared to the actual or physical capacitor bank kvar supplied by a user. If the expected kvar was not realized, the capacitor bank or its switching device may be having some problems. The monitoring location is at the substation; thus, all capacitor banks along the feeders are downstream from the monitoring location. The first capacitor-switching event indicates that two phases of the capacitor are out of service. Either the fuses have blown or the switch is malfunctioning. The second event shows a successful capacitor-switching operation.

Lightning correlation module. The majority of voltage sags and outages in the United States are attributed to weather-related conditions such as thunderstorms. For example, TVA has approximately 17,000 mi of transmission lines where lightning accounts for as much as 45 percent of the faults on their system. The lightning correlation expert system module is designed to correlate lightning strikes with measured power quality events and make that information available in real time directly at the point of measurement. Armed with the correlation results, engineers can evaluate the cause and impact of voltage sags for a specific customer at a specific monitoring point as well as evaluate the impact on all customers for a given event.

When the lightning correlation module detects a voltage sag or transient event, it queries a lightning database via the Internet. The lightning data are provided by the U.S. National Lightning Detection Network operated by Global Atmospheric, Inc. If the query returns a result set, the lightning correlation module will store this information in the monitoring system database along with the disturbance data for information dissemination. The lightning data include the event time of the strike, the latitude and longitude of strike location, the current magnitude, and number of strokes.

Future applications

There are many applications for the intelligent power quality monitoring concept. Some of the more important applications are listed in this section.

- Energy and demand profiling with identification of opportunities for energy savings and demand reduction
- Harmonics evaluations to identify transformer loading concerns, sources of harmonics, problems indicating mis operation of equipment (such as converters), and resonance concerns associated with power factor correction
- Voltage sag impacts evaluation to identify sensitive equipment and possible opportunities for process ride-through improvement
- Power factor correction evaluation to identify proper operation of capacitor banks, switching concerns, resonance concerns, and optimizing performance to minimize electric bills
- Motor starting evaluation to identify switching problems, inrush current concerns, and protection device operation
- Short-circuit protection evaluation to evaluate proper operation of protective devices based on short-circuit current characteristics, time-current curves, etc.

Unit I – Introduction to Power Quality

Two Marks

1. Definition of Power Quality

(NOV/DEC 11, APR/MAY 11, NOV/DEC 10)

Power quality means supply of the power within the permitted variation of the voltage and frequency and without any deviation of sinusoidal waveform in balanced condition.

Power quality is any deviation of the voltage or current waveform from its normal sinusoidal wave shape. These disturbances include, but are not limited to sag, overvoltage, interruption, swell and any other distortions to the sinusoidal waveform.

2. Define voltage swell

(NOV/DEC 09)

A swell is defined as an increase to between 1.1 pu and 1.8 pu in rms voltage or current at the power frequency durations from 0.5 to 1 minute

3. Define momentary interruption?

(APR/MAY 08)

Momentary interruption is said to occur when the RMS voltage decreases less than 0.1 per unit for time duration of 0.008333 second to 3 second.

4. Define voltage sag

(NOV/DEC 09,10)

Sag (dip) a decrease to between 0.1 and 0.9 pu in rms voltage or current at the power frequency for durations of 0.5 cycles to 1 minute. Voltage sag is defined as a decrease in RMS voltage magnitude lasting from 0.5 to 30 cycles.

5. Define over voltage

(APR/MAY 08)

Over voltage is an increase in the rms ac voltage greater than 110 percent at the power frequency for duration longer than 1 min. Over voltages is usually the result of load switching (e.g., switching off a large load or energizing a capacitor bank). The over voltages result because either the system is too weak for the desired voltage regulation or voltage controls are inadequate. Incorrect tap settings on transformers can also result in system over voltages.

6. Define Interruption

(NOV/DEC 10)

An **interruption** occurs when the supply voltage or load current decreases to less than 0.1 pu for a period of time not exceeding 1 min.

7. Why is power quality so important? (APR/MAY 11, MAY/JUN 12)

Power quality is an increasingly important issue for all businesses. Problems with powering and grounding can cause data and processing errors that affect production and service quality.

1. **Lost production:** Each time production is interrupted, your business loses the margin on the product that is not manufactured and sold.
2. **Damaged product:** Interruptions can damage a partially complete product, cause the items to be rerun or scrapped.
3. **Maintenance:** Reacting to a voltage disruption can involve restoring production, diagnosing and correcting the problem, clean up and repair, disposing of damaged products and, in some cases, environment costs.
4. **Hidden costs:** If the impact of voltage sag is a control error, a product defect may be discovered after customer delivery. The costs of losing repeat sales, product recalls and negative public relations can be significant and hard to quantify.

8. What causes power quality problems? (APR/MAY 11, MAY/JUN 12)

Most causes can be divided into two categories:

1. **Internal causes:** Approximately 80 percent of electrical disturbances originate within a business facility. Potential culprits may include large equipment start-up or shutdown, improper wiring and grounding, overloaded circuits or harmonics.
2. **External causes:** About 20 percent of power quality problems originate with the utility transmission and distribution system. The most common cause is a lightning strike; other possibilities include equipment failure, vehicle accidents, weather conditions, neighboring business, and even normal operation of utility equipment.

9. Define total harmonic distortion.

Total harmonic distortion is the term used to describe the net deviation of a non linear waveform from ideal sine wave characteristics. THD is the ratio between the RMS value of the harmonics and the RMS value of the fundamental.

10. Define total demand distortion.

The total demand distortion is defined as the square root of the sum of the squares of the RMS value of the currents from 2nd to the highest harmonic divided by peak demand load current and is expressed as a percent.

11. What are the various power quality issues? (NOV/DEC 11)

1. Power frequency disturbance
2. Power factor
3. Power system transients
4. Grounding and bonding
5. Electro magnetic interference
6. Power system harmonics

12. Define power frequency variations? (APR/MAY 11)

Power frequency variations are a deviation from the nominal supply frequency. The supply frequency is a function of the rotational speed of the generators used to produce the electrical energy.

13. List any four standards available in power quality.

IEEE power quality standards: Institute Of Electrical and Electronics Engineer.

IEEE power quality standards: International Electro Technical Commission.

IEEE power quality standards: Semiconductor Equipment and Material International.

IEEE power quality standards: The International Union for Electricity Applications.

14. Name any four IEC standards that define power quality. (NOV/DEC 11)

1. Definitions and methodology 61000-1-X
2. Environment 61000-2-X
3. Limits 61000-3-X
4. Tests and measurements 61000-4-X
5. Installation and mitigation 61000-5-X
6. Generic immunity and emissions 61000-6-X

15. Define voltage fluctuation.

(NOV/DEC10, APR/MAY11)

Voltage fluctuation is rapid changes in voltage with the allowable limits of voltage magnitude of 0.95 to 1.05 of nominal voltage.

16. Define voltage imbalance.

(NOV/DEC10)

Voltage imbalance or Voltage unbalance is the deviation of each phase from the average voltage of all three phases.

17. What are the effects of power quality problems? (APR/MAY 11, MAY/JUN 12)

1. The effects of power quality problems can be understood by looking at the various types of loads that are affected by power quality problems, including computers, consumer products, lighting, meters, aeromagnetic equipment, telephones, manufacturing processes and capacitors.
2. Computers and computer controlled equipment are most subject to power quality problems. They freeze up and lose data. Most power quality problems on computers are caused by voltage variations.

18. List out the IEEE and IEC standards.

(NOV/DEC 11)

IEEE standards:

1. IEEE Std 519-1992, IEEE Recommended practices and requirements for Harmonic control in Electric power systems.
2. IEEE Std 1159-1995, IEEE Recommended practices for monitoring electrical power quality.

IEC standards:

1. Definitions and methodology 61000-1-X
2. Environment 61000-2-X
3. Limits 61000-3-X
4. Tests and measurements 61000-4-X
5. Installation and mitigation 61000-5-X
6. Generic immunity and emissions 61000-6-X

19. Differentiate between sag and swell.

Voltage sag is an event in which the RMS voltage decreases between 0.1 and 0.9 pu at the power frequency. It lasts for duration of cycles to 1 min

Swell is an event in which the RMS voltage increases between 1.1 and 1.8 pu at the power frequency. It lasts for duration of 0.5 cycles to 1 min

20. What are the causes of sags?

1. Voltage sags are usually associated with system faults but can also be caused by the switching of heavy loads.
2. Voltage sags are caused by motor starting.

16 Marks Questions

1. Explain The Long Duration Voltage Variation (APR/MAY 08,NOV/DEC 11)
2. Explain The Short Duration Voltage Variation (APR/MAY 08,NOV/DEC 11)
3. Explain The Different Types Of Waveform Distortion (MAY/JUN12)
4. Explain The Transients? (APR/MAY 09, NOV/DEC 10, NOV/DEC 11 &MAY/JUN12)
5. Explain the power quality issues? (or) Explain power quality terms (APR/MAY11,NOV/DEC 11& MAY/JUN12)
6. Explain Sources and Effects of power quality problems with suitable examples. (MAY/JUN12)

Unit II – Voltage Sags and Interruptions

Two Marks

1. Define short interruption?

(NOV/DEC 10)

When the supply is restoring automatically the resulting event is called short interruption.

2. Define long interruption?

(APR/MAY 11)

When the supply is restoring manually the resulting event is called long interruption.

3. Define during fault period.

The low impedance path between the faulted phase and ground is still present so that the voltage in the faulted phase remains zero or close to zero. It is called the during fault period.

4. Define post fault period.

The fault has extinguished the short circuit has now an open circuit because the breaker in that phase is still open. It is called the post fault period.

5. What are the input data's for prediction of short interruption?

Stochastically predict the number of interruptions experienced by a customer fed from a certain feeder, the following input data is required.

1. Failure rate per km of feeder, different values might be used for the main and for the lateral conductors
2. Length of main feeder and of the lateral conductors
3. Success rate of reclosure if multiple reclosure attempts are used: success rate of first reclosure of the second reclosure.
4. Position of reclosing breakers and fuses.

6. What are the assumptions for prediction of short interruption?

1. The failure rate of main feeder is: 0.1 faults per year per km of feeder.
2. The failure rate of lateral conductor is: 0.25 faults per year per km of feeder.

3. The success rate of the first reclosure is 75% thus in 25% of the cases a second trip and reclosure are needed.
4. The success rate of the second attempt is 10% of the number of faults. Thus for 15% of the faults the second attempt does not clear the fault. Those faults are permanent faults leading to long interruption.

7. What is the reclosing procedure for prediction of short interruption?

1. The circuit breaker opens instantaneously on the over current due to fault.
2. The circuit breaker remains open for a short time 75% of the faults clears in this period.
3. The circuit breaker closes. If the fault is still present the breaker again opens instantaneously on over current. This is required in 25% of the cases.
4. The circuit breaker now leaves a longer dead time. Another 10% of the faults clear in this period.
5. The circuit breaker closes for a second time. If the fault is still present the breaker remains closed until the fuse protecting the lateral conductor has had time to blow.
6. If the fault is still present after the time needed for the fuse to clear the fault, the breaker opens for a third time and now remains open. Further reclosure has to take place manually and the whole feeder will experience a long interruption.

8. Define failure.

The term failure is used in the general meaning of the term: a device or system which does not operate as intended.

9. Define outage.

(NOV/DEC 10)

An outage is the removal of a primary component from the system.

Example: A transformer outage or the outage of a generator station.

A failure does not lead to an outage.

10. Define interruption.

The term interruption is the situation in which a customer is no longer supplied with electricity due to one or more outages in the supply. In reliability evaluation the term interruption is used as the consequence of an outage or number of overlapping outages.

11. What are the causes of long interruptions?

(NOV/DEC 11)

1. Fault occurs in the power system which leads to an intervention by the power system protection. If fault occurs in a part of the system which is not redundant or of which the redundant part is out of operation the intervention by the protection leads to an interruption for a number of customers or pieces of equipment.
2. A protection relay intervenes incorrectly thus causing a component outage which might again lead to long interruption. If the incorrect tripping occurs in a part of the system without redundancy.

12. Define direct cost

(NOV/DEC 10)

These are the costs which are directly attributable to the interruption.

Example:

For domestic customers is the loss of food in refrigerator. For industrial customers is the direct cost consist lost of raw material, lost production, and salary cost during the non productive period. For commercial customers the direct costs are the loss of profit and salary costs during the non productive period.

13. Define Indirect cost

The indirect cost are much harder to evaluate and in many cases not simply to express in amount of money.

Example:

A company can lose future orders when an interruption leads to delay in delivering a product. For domestic customer can decide to take an insurance against loss of freezer contents. For commercial customers might install a battery backup. For industrial customers could even decide to an area with less supply interruptions.

14. What is meant by single phase tripping?

Single phase tripping is used in transmission systems to maintain synchronicity between both sides of a line. Single phase tripping is rarely used in distribution or low voltage systems. Not only it requires more expensive equipment, but it will also reduce the chance of a successful reclosure. The fault current continues to flow via the non

faulted phases. This reduces the chance that the fault will extinguish and thus increases the number of reclosure attempts and the number of long interruptions.

15. What are types of power system reliability?

The reliability of power system protection is split into two aspects,

1. Dependability
2. Security
3. Dependability is the degree of certainty that the protection will operate correctly. The Security is the degree of certainty that the protection will not operate correctly.

16. List out the applications of utility side. (APR/MAY 11)

1. Three independently controlled regulators may be used for better balance between the phase voltages.
2. The purpose of line drop compensator is to regulate the voltage profile so that it provides the necessary voltage boost at peak load and keep the voltage closer to nominal at lower loads.

17. List out the applications of end user side. (APR/MAY 11)

1. Capacitor application is used for voltage regulation.
2. The primary motivation is to eliminate utility power factor penalties.
3. Adding capacitors results in power quality problems.
4. Harmonic problems.
5. If power factor correction capacitors are not harmonic sources, they can interact with the system to attenuate the harmonics that are already there.

16 Marks

1. Explain the origin of short Interruptions? (MAY/JUN 09,NOV/DEC 11)
2. Explain the monitoring of short Interruptions? (NOV/DEC 11)
3. Explain the Principles of regulating the voltage and Voltage regulating devices (NOV/DEC 10& NOV/DEC 11)
4. Explain the Prediction of short Interruptions.

Unit III – Over Voltages

Two Marks

1. Define voltage sag

(APR/MAY 08)

Sag (dip) a decrease to between 0.1 and 0.9 pu in rms voltage or current at the power frequency for durations of 0.5 cycles to 1 minute. Voltage sag is defined as a decrease in RMS voltage magnitude lasting from 0.5 to 30 cycles.

2. Name any four types of sag mitigation devices

1. Dynamic voltage restorer
2. Active series compensators
3. Distribution static compensator
4. Solid state transfer switches.

3. What are the causes of over voltages in electric power systems?

1. Load switching off
2. Capacitor switching on
3. System voltage regulation

4. What is meant by shielding of cables?

(APR/MAY 09)

Shielding is the use of a conducting and/or ferromagnetic barrier between a potentially disturbing noise source and sensitive circuitry.

Shields are used to protect cables and electronic circuits. It may be in the form of metal barriers, enclosures, wrapping around source circuits and receiving circuits

5. How power quality problems created by lightning stroke?

The chief power quality problems with lightning stroke currents entering the ground system are

1. They raise the potential of the local ground above other grounds in the vicinity by several kilovolts. Sensitive electronic equipment that is connected between two ground references, such as a computer connected to the telephone system through a modem, can fail when subjected to the lightning surge voltages.

2. They induce high voltages in phase conductors as they pass through cables on the way to a better ground.

6. Define Ferro resonance.

Ferro resonance an irregular, often chaotic type of resonance that involves the nonlinear characteristic of iron-core (ferrous) inductors. It is nearly always undesirable when it occurs in the power delivery system, but it is exploited in technologies such as constant-voltage transformers to improve the power quality.

7. List the important types of arrestor used in protection of cable.

1. Under oil arresters
2. Elbow arresters
3. Lower discharge arresters

8. What is shielding?

Shielding is the use of a conducting and/or ferromagnetic barrier between a potentially disturbing noise source and sensitive circuitry. Shields are used to protect cables (data and power) and electronic circuits. They may be in the form of metal barriers, enclosures, or wrappings around source circuits and receiving circuits.

9. Write the principle of over voltage protection.

The fundamental principles of over voltage protection of load equipment are

1. Limit the voltage across sensitive insulation.
2. Divert the surge current away from the load.
3. Block the surge current from entering the load.
4. Bond grounds together at the equipment.
5. Reduce, or prevent, surge current from flowing between grounds.
6. Create a low-pass filter using limiting and blocking principles.

10. What are device can be used for over voltage protection

(NOV/DEC 10, NOV/DEC11)

1. Surge arrester(crowbar & clamping device)
2. Transient over voltage Surge suppresser
3. Isolation transformer
4. Low pass filter
5. Low impedance power conditioners
6. Pre-insertion resistors (transmission and distribution)
7. Pre-insertion inductors (transmission)
8. Synchronous closing (transmission and distribution)
9. Fixed inductors (transmission and distribution)

11. What are the various causes of over voltages?

(NOV/DEC 09)

1. Atmospheric discharges
2. Switching operations in the public grid and low voltage mains
3. Electrostatic discharges
4. Ferro resonance

12. Define transient over voltages?

(NOV/DEC 10, NOV/DEC11)

A transient over voltage can be defined as the response of an electrical network to a sudden change in network conditions either intended or accidental or network simulation.

13. Define impulsive transients?

An impulsive transient is a sudden non power frequency change in the steady state condition of the voltage or current waveforms that is essentially in one direction either positive or negative with respect to those waveforms.

14. Define voltage magnification phenomena?

The highest transient voltages occur at the low voltage capacitor bank when the characteristics frequency of the switching transient is nearly equal to the resonant frequency of the low voltage system and when the switched capacitor is ten or more times the size of the low voltage capacitor.

15. What is the need of surge arrester?

(NOV/DEC11)

- a. A surge arrester is a protective device for limiting surge voltages on equipment by discharging or by passing surge current
- b. Surge arresters allow only minimal flow of the 50HZ/60HZ power current to ground

16. What are the problems associated with Ferro resonance?

1. Transformer over heating
2. Audible noise
3. High over voltages and surge arrester failure

17. How is an over voltage different from swell?

(APR/MAY 09)

Over voltage: when used to describe a specific type of long duration variation, refers to a voltage having a value of at least 10 percent above the nominal voltage for a period of time greater than 1 minute.

Swell: A temporary increase in the RMS value of the voltage of more than 10 percent of the nominal voltage, at the power frequency, for duration from 0.5 cycles to 1 min.

18. What are types of transient over voltages?

Impulsive

Oscillatory

19. What are the causes of voltage magnification on network?

The voltage magnification will not result in capacitor damage. The problem that usually occurs is the failure or mis operation of sensitive loads in the facility where the low voltage capacitors are installed.

20. Give examples for oscillatory transient over voltages.

Switching operations within the distribution network are a major cause of oscillatory transient over voltages. Such operations include,

1. Switching of utility capacitor banks

2. Switching of circuit breakers to clear network faults
3. Switching of distribution feeders to rearrange the network for maintenance or construction

21. Mention two important concerns for capacitor bank switching transients.

1. Voltage transients at the capacitor bank substation and neighbouring substations
2. Power quality impact on sensitive customer loads due to variations in voltage when energizing capacitor banks

22. Mention the benefits of transmission line surge arresters

1. Reduces the height of transmission lines by eliminating shield wire.
2. Improves outage statistics by eliminating back flash over from the tower ground lead to the phase conductor.

23. What is the need of low pass filter in transient protection?

1. This LC combination provides a low impedance path to ground for selected resonant frequencies
2. Low pass filter employ principle to achieve better protection even for high frequency transients.

24. Define lightning phenomenon.

(NOV/DEC11)

Lightning is an electrical discharge in the air between clouds between clouds, between different charge centre within the same cloud, or between cloud and earth.

Even through more discharges occur between or within clouds, there are enough strokes that terminate on the earth to cause problems to power systems and sensitive electronic equipment.

25. List the sources of over voltages.

(NOV/DEC 11)

1. Capacitor switching and lightning all the two main sources of transient over voltages.
2. Switching phenomena on end user facilities also are sources of transient over voltages.

3. Transient over voltages can be generated at higher frequency, medium frequency and also at low frequencies.

16 Marks

1. What are the types and causes of transients? Explain the principle of over voltage protection. **(NOV/DEC 2013)**
2. Explain the use of PSCAD in analyzing the power quality. **(APR/MAY 2008)**
3. Explain the types and causes of transients. **(MAY/JUN12)**
4. Explain the devices for over voltage protection. **(MAY/JUN11)**
5. Explain the capacitor switching transients. **(NOV/DEC 10, NOV/DEC 11)**
6. Explain the lightning transients. **(NOV/DEC 11)**

Unit IV – Harmonics

Two Marks

1. Define harmonics?

(ARR/MAY 08)

Harmonics is a sinusoidal components having a frequency that is an integral multiple of the fundamental frequency. Thus, a pure voltage or current sine wave has no distortion and no harmonics, and a non-sinusoidal wave has distortion and harmonics. To quantify the distortion, the term total harmonic distortion (THD) is used. The term expresses the distortion as a percentage of the fundamental (pure sine) of voltage and current waveforms.

2. Give at least two IEC standards for EMC.

(ARR/MAY 08)

IEC 61000-2-2 (1993): Electromagnetic compatibility. Part 2: environment. Section 2: compatibility levels for low frequency conducted disturbances and signaling in public low voltage power supply systems.

IEC 61000-3-2 (2000): Electromagnetic compatibility part3: limits section 2: limits for harmonic current.

3. Define harmonic indices?

(NOV/DEC 09,10)

The power quality industry has developed certain index values that help us assess the quality of service as it relates to distortion caused by the presence of harmonics. These values or harmonic indices serve as a useful metric of system performance. The two most commonly indices are

1. Total Demand Distortion
2. Total Harmonic Distortion

4. Mention the devices for controlling harmonic distortion?

(NOV/DEC 09, 10)

1. Series reactors
2. Zigzag transformers
3. Specially connected transformers

5. Give the IEC standard to define harmonics.

(MAY/JUN 09)

The International Electro technical Commission (IEC) has defined a category of electromagnetic compatibility standards that deal with power quality issues. The term electromagnetic compatibility includes considerations for both radiated and conducted interference with customer equipment.

6. What is crest factor?

The crest factor of any waveform is the ratio of the peak value to the RMS value. In a perfect sine wave, the crest factor is 1.414. Crest factors different than 1.414 indicate distortion in the waveform. Typically distorted current waveforms have crest factors higher than 1.414, and distorted voltage waveforms have crest factors lower than 1.414. Distorted voltage waveforms with crest factors lower than 1.414 are called “flat top” voltage waveforms.

7. What kind of equipment is needed to measure distorted waveforms?

A digital oscilloscope is needed to measure the wave shape, THD and amplitude of each harmonic. However, if we simply want to measure the RMS value of the waveform, a “True-RMS” multi meter will suffice. The term “True-RMS” is used because not all instruments give correct readings when measuring distorted waveforms.

8. Define TDD

(ARR/MAY 11,NOV/DEC11)

Total Demand Distortion (TDD) The ratio of the root mean square of the harmonic current to the rms value of the rated or maximum demand fundamental

Current, expressed as a percent.

9 .Define THD

(ARR/MAY 08,11 & NOV/DEC 10,11)

Total Harmonic Distortion (THD) The ratio of the root mean square of the harmonic content to the rms value of the fundamental quantity, expressed as a percent of the fundamental.

11. What is the reason for existence of harmonic distortion?

Harmonic distortion exists due to the harmonic characteristics of the devices and loads on the power system. These devices act as current sources that inject harmonic currents into the power system.

12. What is voltage and current distortion?

1. Voltage distortion is any deviation from the nominal sine waveform of the ac Line voltage
2. Current distortion is any deviation from the nominal sine waveform of the ac line current

13. Mention the applications of cyclo converter.

1. Steel rolling mill end tables
2. Cement mill furnaces
3. Mine hoists
4. Ship propulsion drives

14. List the some dynamic correction of power quality events.

- a. Resonance preventive
- b. Power factor correction
- c. Dynamic VAR compensation

15. What is current source inverter?

The current source inverter receives DC power from an adjustable current source and adjusts the frequency and current.

16. Define inter harmonics. (MAY/JUN 09, 10,12)

Voltages or currents having frequency components that are not integer multiples of the frequency at which the supply system is designed to operate is called inter harmonics.

17. Give at least two IEEE standards for harmonics. (MAY/JUN 09, 11)

IEEE Std 519-1992, IEEE Recommended practices and requirements for Harmonic control in Electric power systems.

IEEE Std 1159-1995, IEEE Recommended practices for monitoring electrical power quality.

18. What is the classification of active harmonic conditioner?

Active harmonic conditioners can be broadly classified into three categories

- a. Series conditioners
- b. Parallel conditioners
- c. Hybrid conditioners

19. Mention the harmonic sources from industrial loads

Three phase converter with adjustable speed drives(DC drives and AC drives)

Arcing devices (Arc furnaces, welders, discharge lamps etc)

Saturable devices (transformer, electromagnetic devices with steel core)

20. State the principles of controlling harmonics. (APR/MAY 11)

There are many number of devices available to control harmonic distortion. They can be as simple as a capacitor bank or a line reactor or as complex as an active filter.

16 Marks

1. Explain briefly about fundamentals of waveform distortion and the effects of harmonic distortion. (NOV/DEC 2013)
2. Explain the principles of controlling harmonics and its standards and limitations. (NOV/DEC 2013)
3. Explain the power system response characteristics (NOV/DEC 11)
4. Explain the principle of controlling harmonic distortion? (APR/MAY 08)
5. Explain Sources and effects of harmonic distortion. (APR/MAY 11)

Unit V – Power quality Monitoring

Two Marks

1. What are all power quality measuring equipment ?

1. Wiring and grounding test devices
2. Multi meters
3. Oscilloscopes
4. Disturbance analyzers
5. Harmonic analyzers and spectrum analyzers
6. Combination disturbance and harmonic analyzers
7. Flicker meters
8. Energy monitors

2. Define spectrum.

A range of frequencies within waves have some specified common characteristic, for example, audio frequency system..

3. Define Harmonic Analyzers

Harmonic analyzers have several capabilities. They capture harmonic waveforms and display them on a screen. They calculate the K factor to derate transformers and the total harmonic distortion (THD) in percent of the fundamental

4. What are the parameters to be monitor for identify the power quality problems?

Power quality encompasses a wide variety of conditions on the power system. Important disturbances can range from very high frequency impulses caused by lightning strokes or current chopping during circuit interruptions to long-term over voltages caused by a regulator tap switching problem.

5. Define expert system.

It is the one of the soft computing method, it is an area of computer since concerned with designing intelligent computer systems, that is exhibit the characteristics we associate with intelligence in human behavior.

6. What are the types of power quality measurement equipment?

(APR/MAY08)

1. Hand held single phase power quality monitors
2. Portable three phase power quality monitors
3. Harmonic analyzers
4. Distortion analyzers
5. Multi meters

7. What is meant by power quality monitoring?

(NOV/DEC 09)

Power quality monitoring should be an integral part of the design for high reliability facilities. The monitoring will characterize the performance of the supply system and the performance of power conditioning equipment at the facility, including possible interaction issues with facility loads.

8. What are the purposes of power quality monitoring system?

- a. Preventive maintenance
- b. Load analysis
- c. Equipment diagnostics
- d. Long time surveys

9. What are the characteristics of power line monitors?

1. Portable, rugged, lightweight
2. Simple to use, with proper training
3. Designed for long term unattended recording
4. Definition of line disturbance parameters varies between manufactures

10. What is spectrum analyzer?

An instrument used for the analysis and measurement of signals throughout the electromagnetic spectrum. Spectrum analyzers are available for sub audio, audio, and radio frequency measurements, as well as for microwave and optical signal measurements.

11. What is tracking generator?

The tracking generator enhances the applications of spectrum analyzers. Its output delivers a swept signal whose instantaneous is always equal to the input tuned frequency of the analyzer.

12. Mention some examples of flicker sources

- a. Arc furnaces
- b. Welding machines
- c. Wind turbines

13. Give an application of capacitive dividers.

(May/Jun 09)

1. Capacitive divider network is employed for measurement of very high frequency components in the voltage level of substation.
2. Some application requires a special purpose capacitor dividers can be obtained for measurements requiring accurate characterization of transients up to at least 1 Mhz.

14. What is the operation of spectrum analyzer?

- A spectrum analyzer separates the signal into two components: amplitude (displayed vertically) and frequency (displayed horizontally). In some low frequency analyzers, phase information can also be displayed.
- Low frequency analyzers are some times called as harmonic analyzers.
- Vertical scale displayed the amplitude and horizontal scale displays the frequency.

15. What is the use of spectrum analyzer?

A spectrum analyzer can be used for trace of high frequency harmonics.

16. Mention the factors that should be considered for selecting the instrument.

1. Number of channels
2. Temperature specifications of the instrument
3. Input voltage range
4. Ability to measure three phase voltages

17. Mention the instruments used for the analysis of non sinusoidal voltage and currents.

1. Oscilloscope
2. Spectrum analyzer
3. Harmonic analyzer

18. Mention the basic categories of instruments for harmonic analysis.

1. Simple meters
2. General purpose spectrum analyzers
3. Special purpose power system harmonic analyzers

4. Digital harmonic measuring equipment
5. Distortion analyzers
6. Data logger

19. Define voltage flicker according to IEEE standard 1159.

Voltage fluctuation is the response of the power system to the varying load and light flicker is the response of the lighting system as observed by the human eye

20. Define voltage flicker?

According to IEC-868 std. voltage flicker is defined as the perceived variation in light intensity from a lamp as a result of the modulation or fluctuation in the amplitude of the voltage at low frequencies.

16 Marks

1. Write short note on the power quality Monitoring Considerations (NOV/DEC 11, MAY/JUN12)
2. Briefly explain the Spectrum analyzers and harmonic analyzer (APR/MAY 08, MAY/JUN 09)
3. With neat sketch explain the operation Flicker meters (APR/MAY 08,10,,NOV/DEC 09,10,11)
4. Explain the active filters (APR/MAY 10,12, NOV/DEC 11)
5. Explain how the expert systems can be utilized for power quality problems (APR/MAY 08, MAY/JUN 09, 10, NOV/DEC 09)
6. Explain Deregulation effect on power quality monitoring. (APR/MAY 11)
7. Explain power quality measurement equipments and power conditioning equipments. (NOV/DEC 11)